

Michel Paradis
McGill University

BILINGUAL APHASIA TEST

(DUTCH VERSION)

STIMULUS BOOK

NEDERLANDS

The development of the Bilingual Aphasia Test materials was supported by Grant MEQ 01-07-k (1976-1983) from the Quebec Ministry of Intergovernmental Affairs, Grant EQ 1660 (1980-1985) from the Quebec Ministry of Education FCAC Fund, and Grants 410-83-1028 (1984, 1985) and 410-88-0821 (1989-1991) from the Social Sciences and Humanities Research Council of Canada.

AUDITIVO-VERBAAL ONDERSCHIEDINGSVERMOGEN

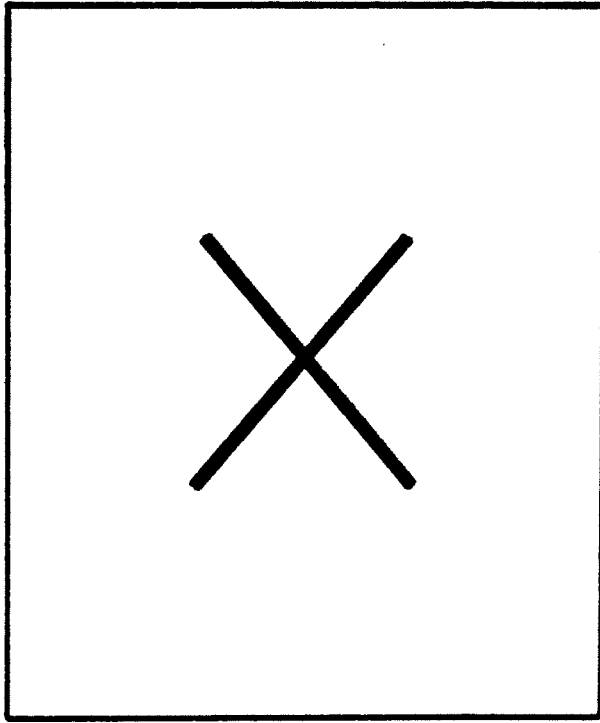

1

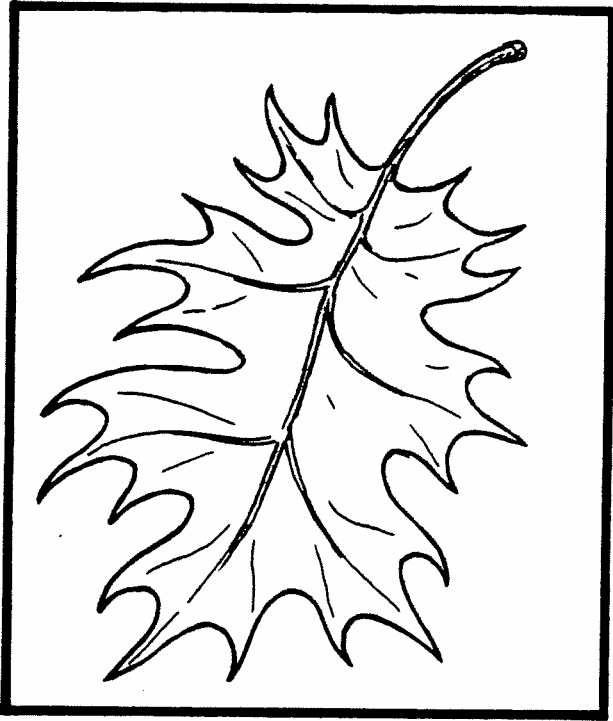

2



3

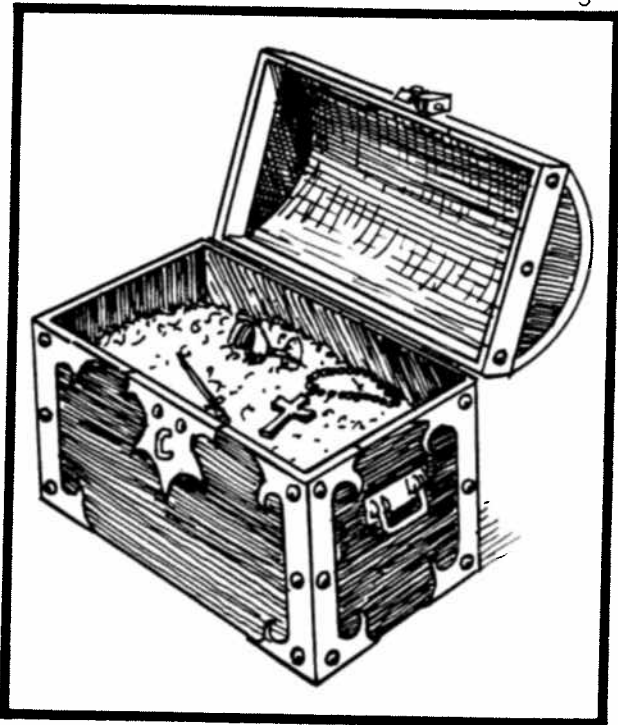

4

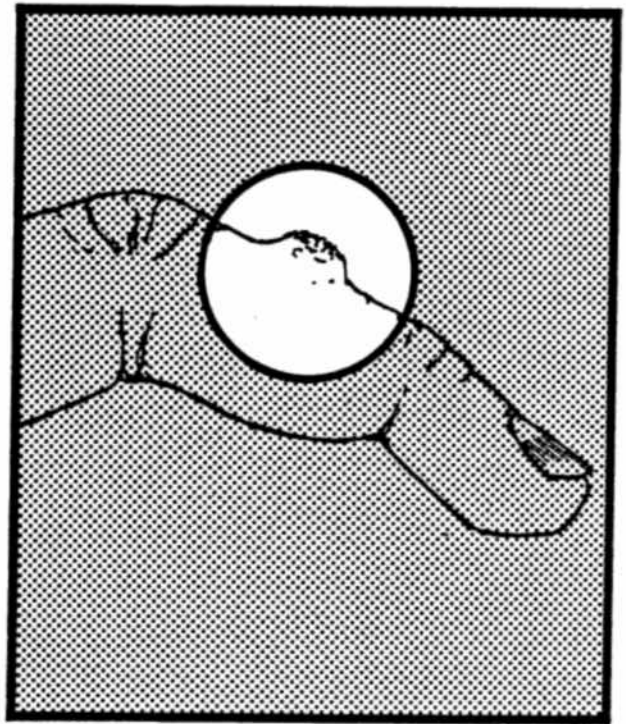

Voorbeeld

1

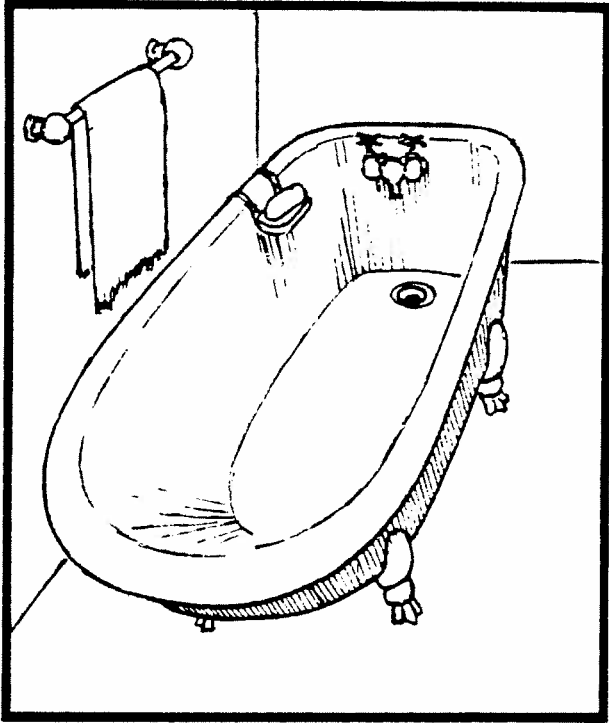

2



3

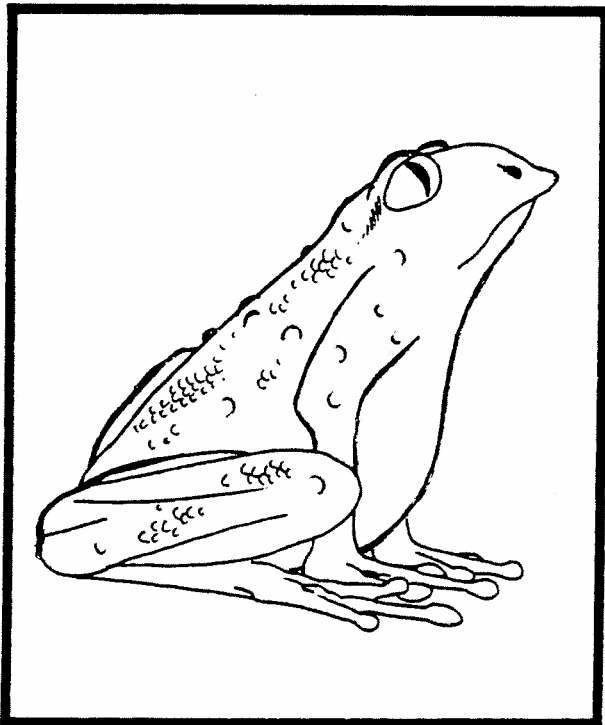

4



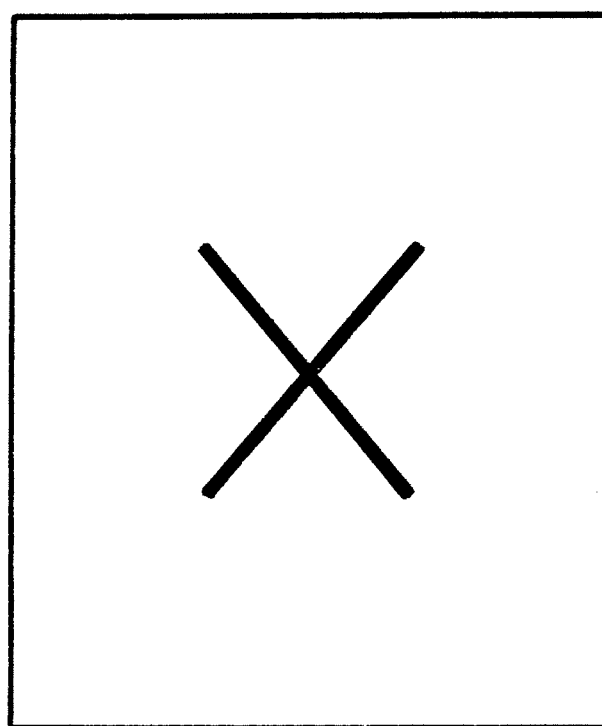

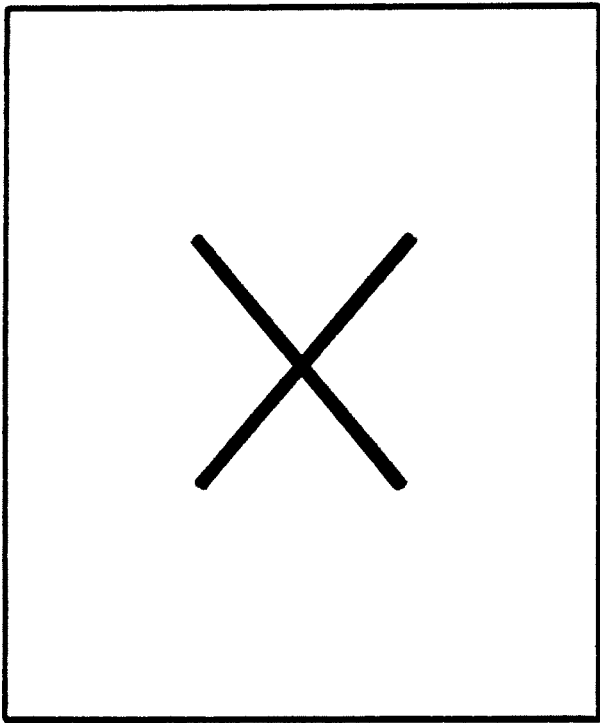

1

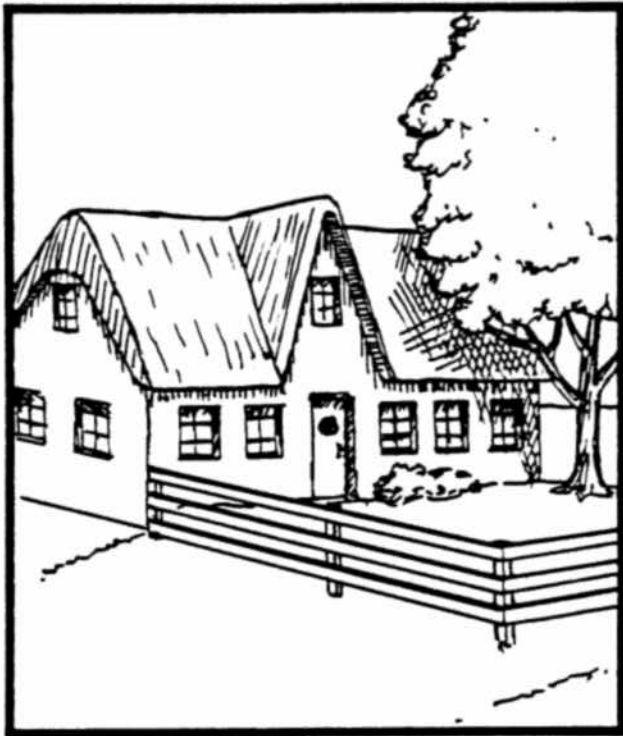

2

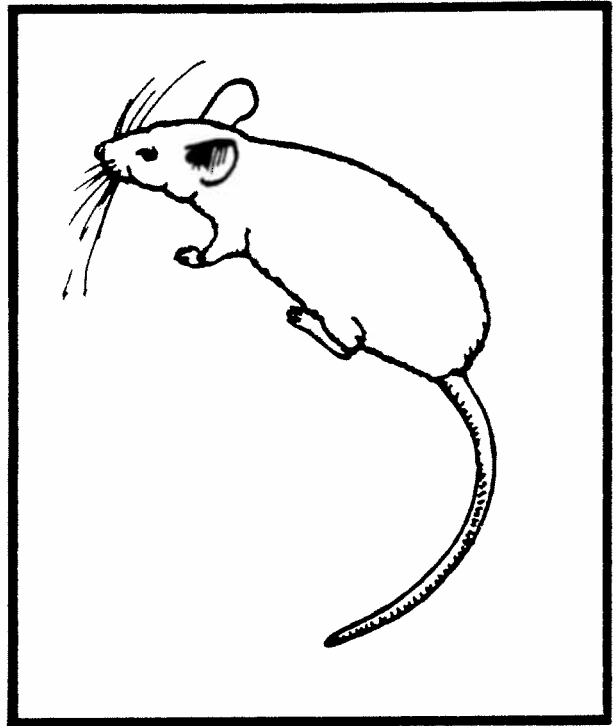

3

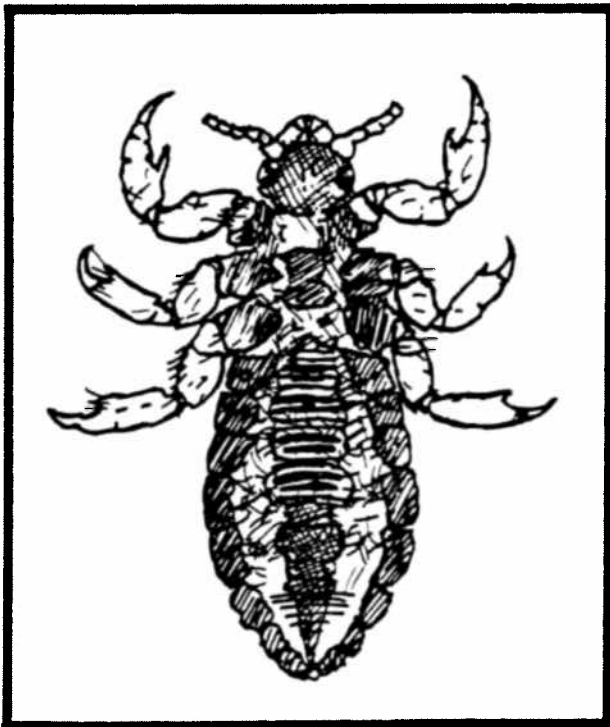

4

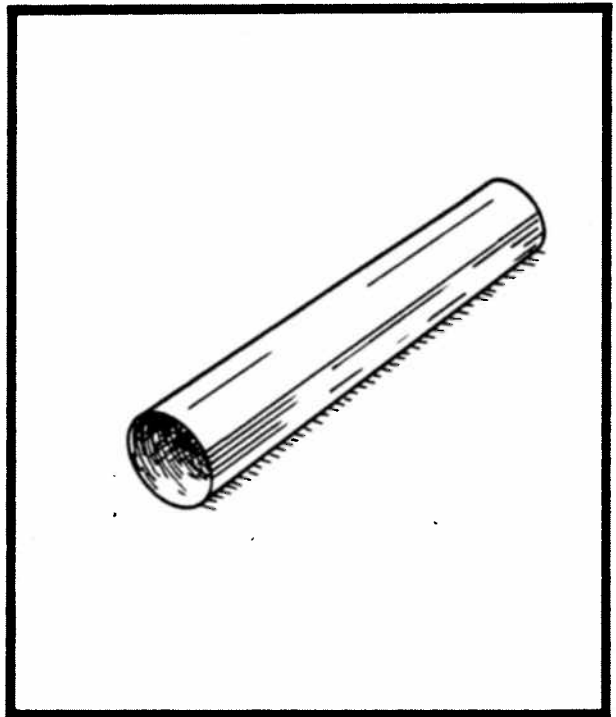

1

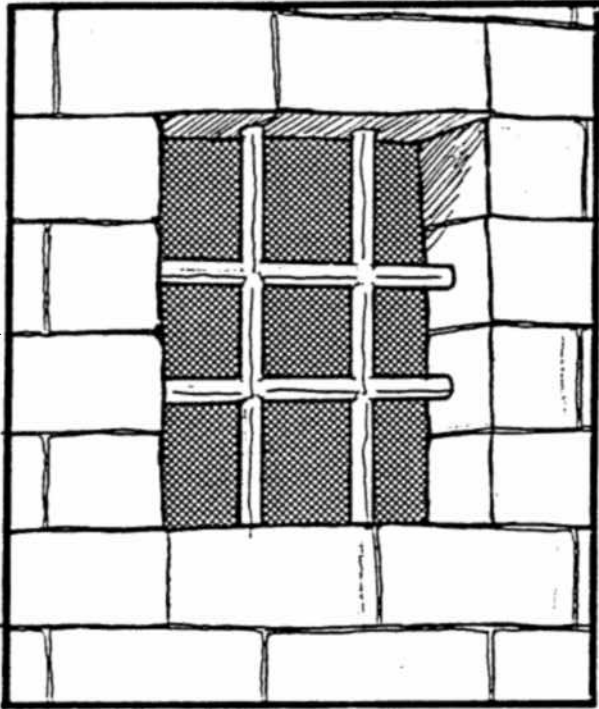

2

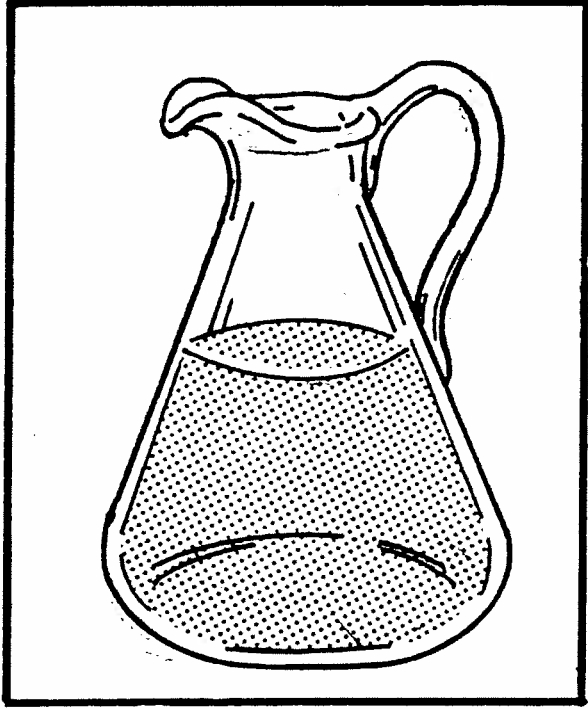

3

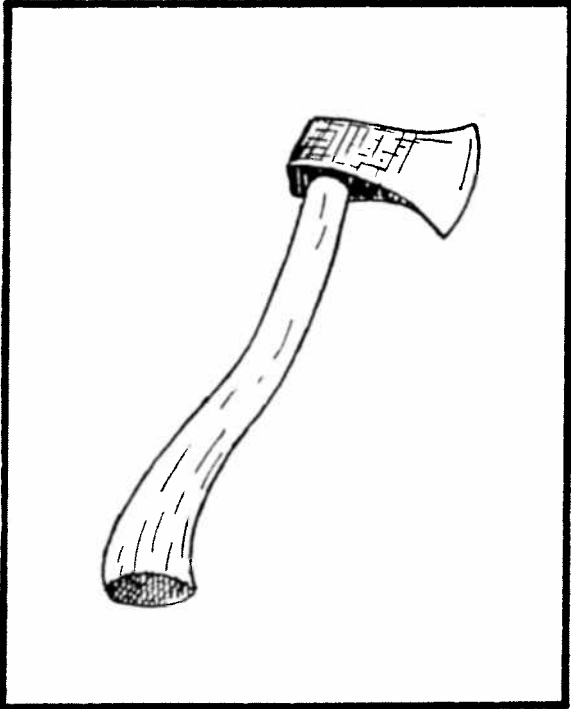

4

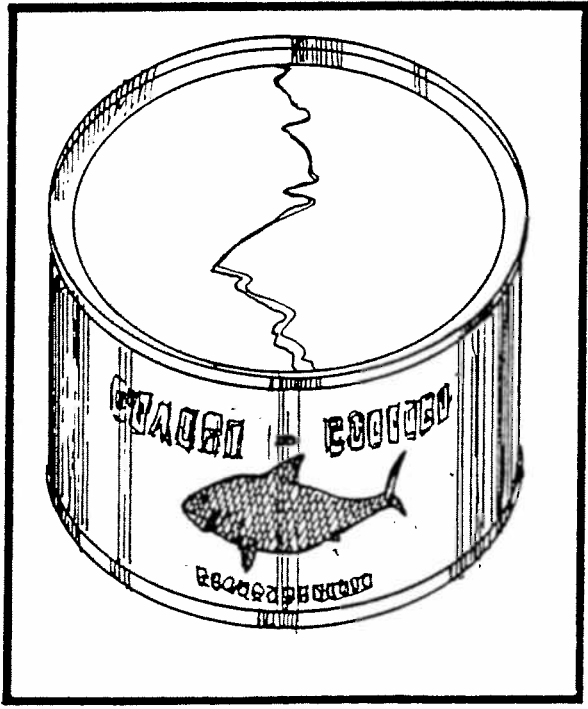

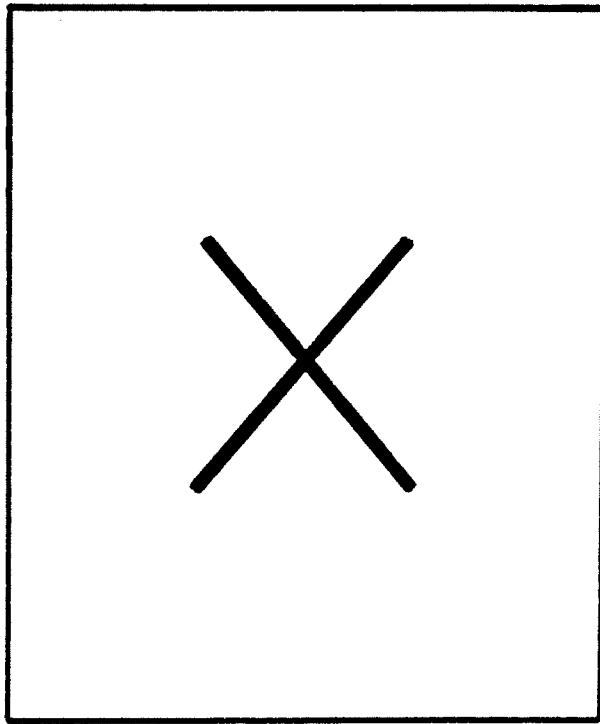

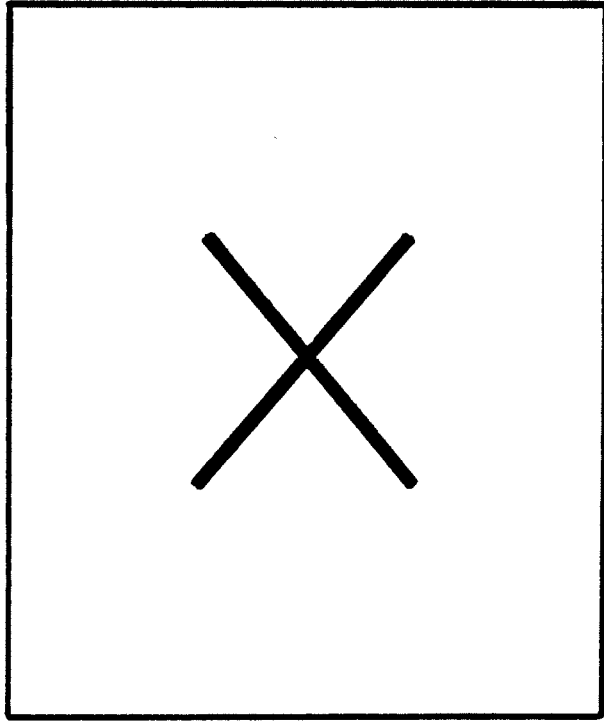

1

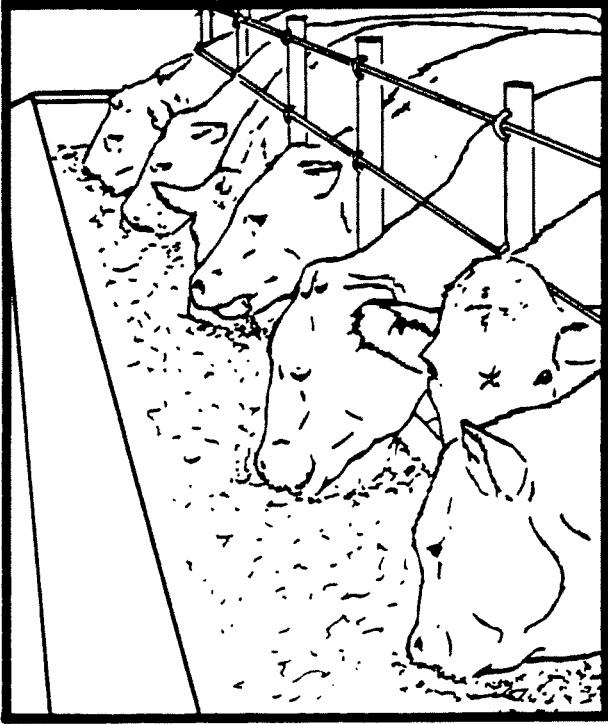

2



3

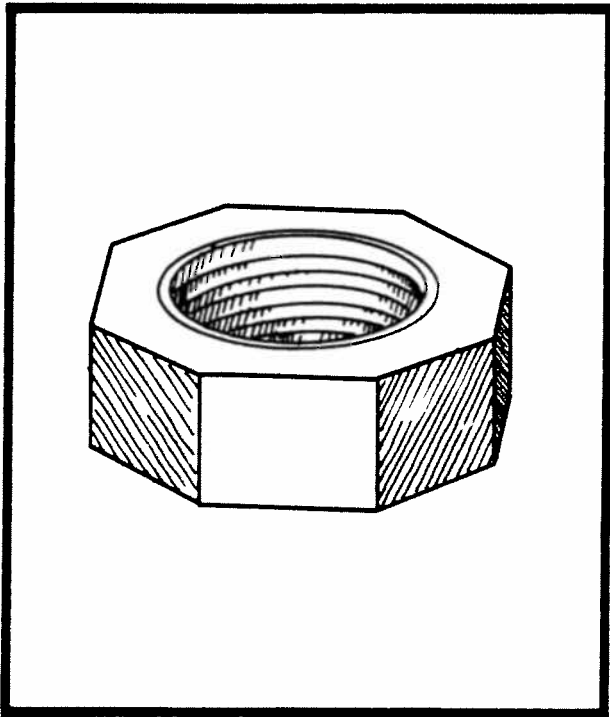

4

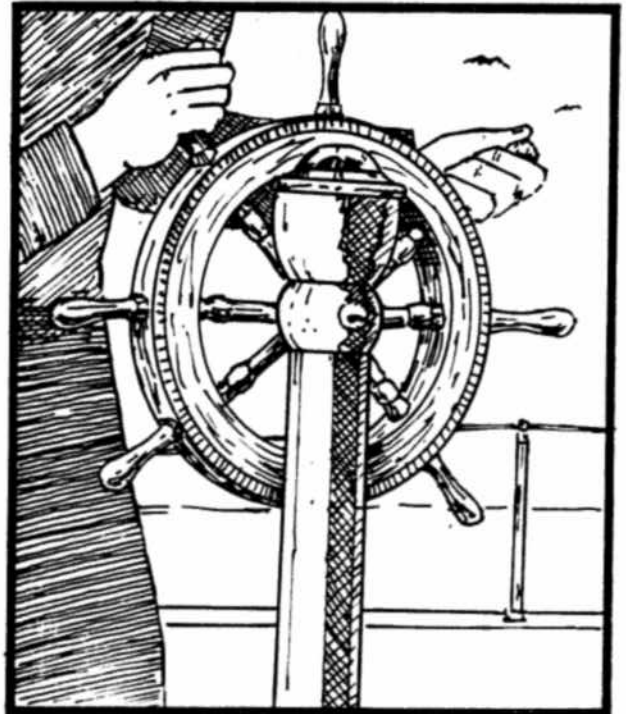

1

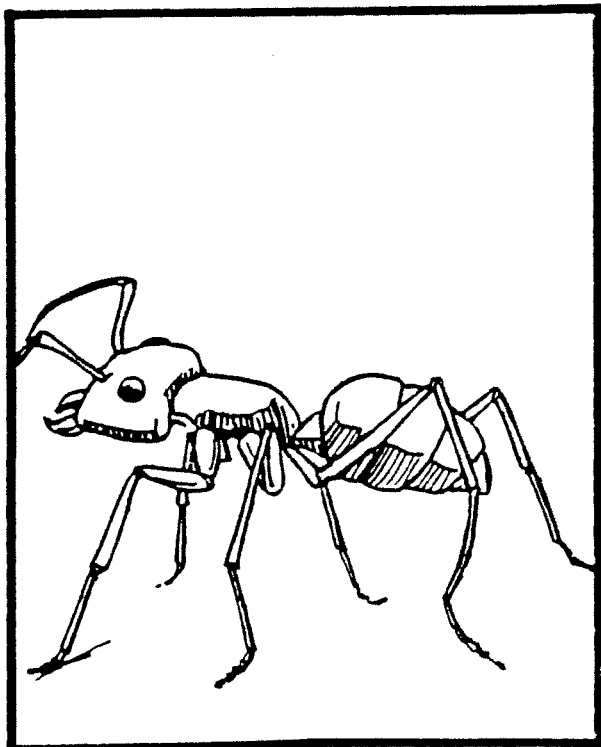

2

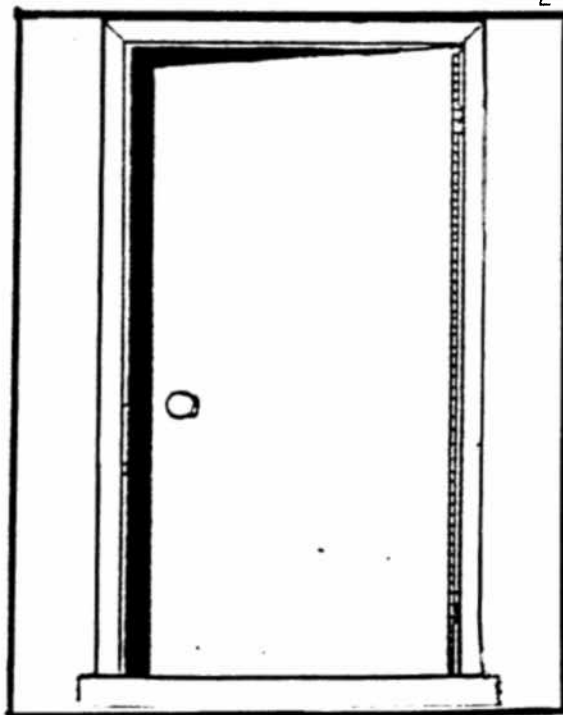

3

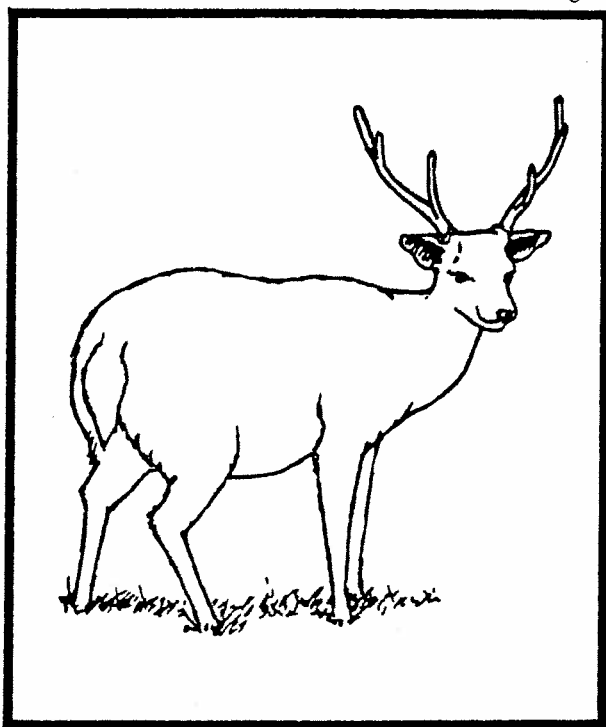

4

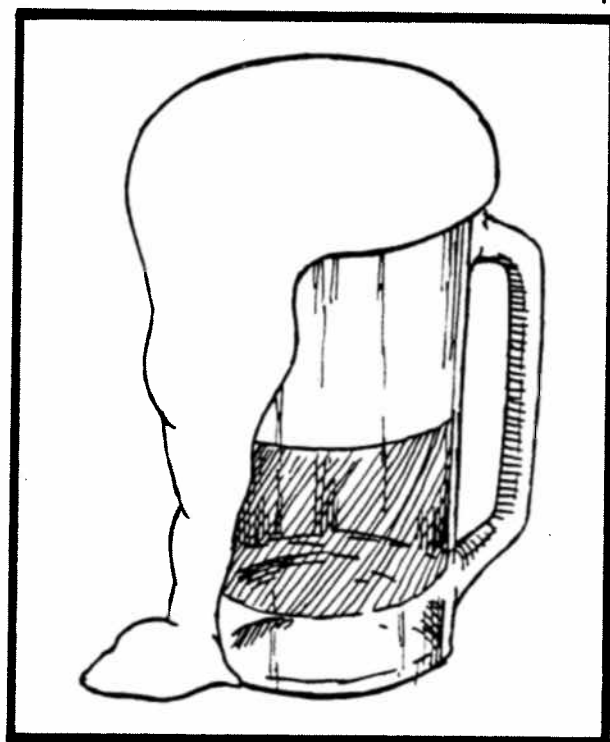

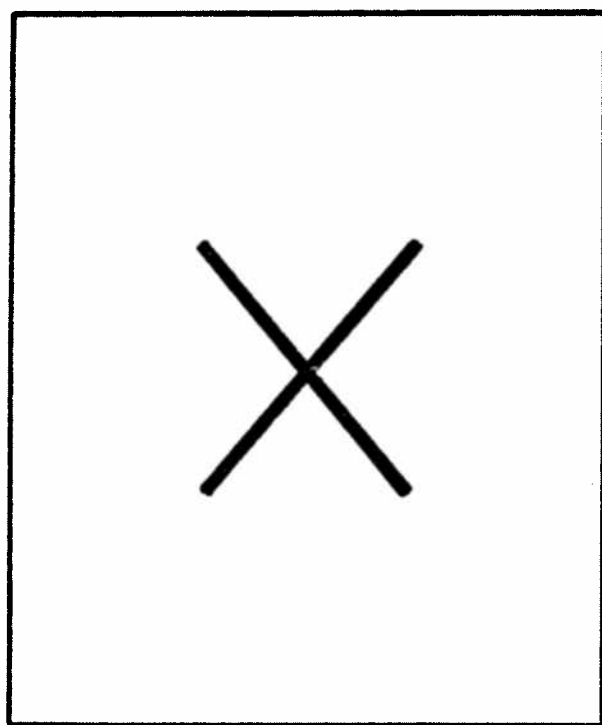

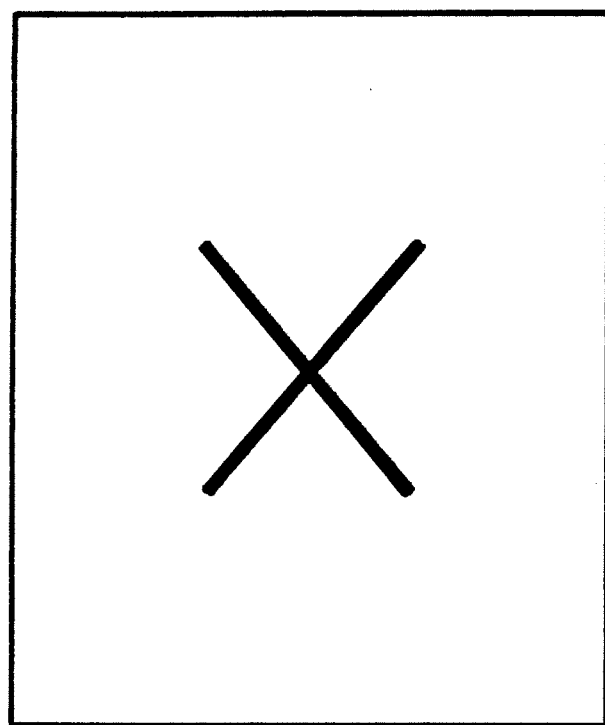

1

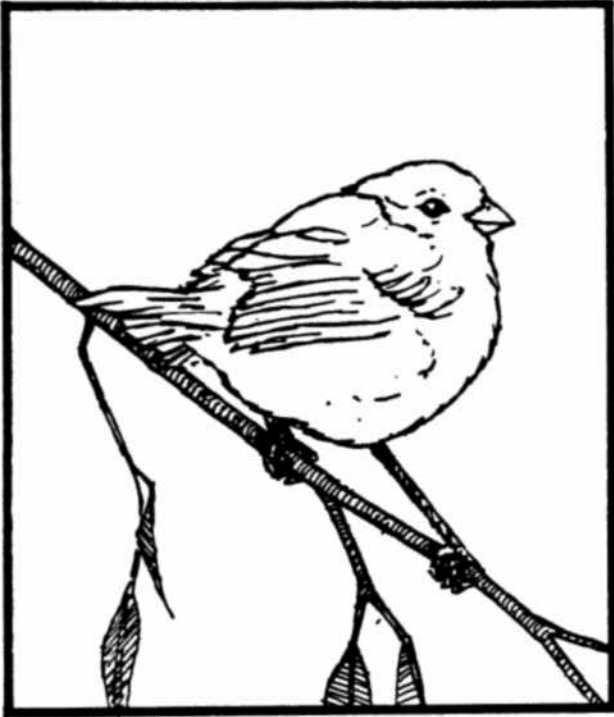

2

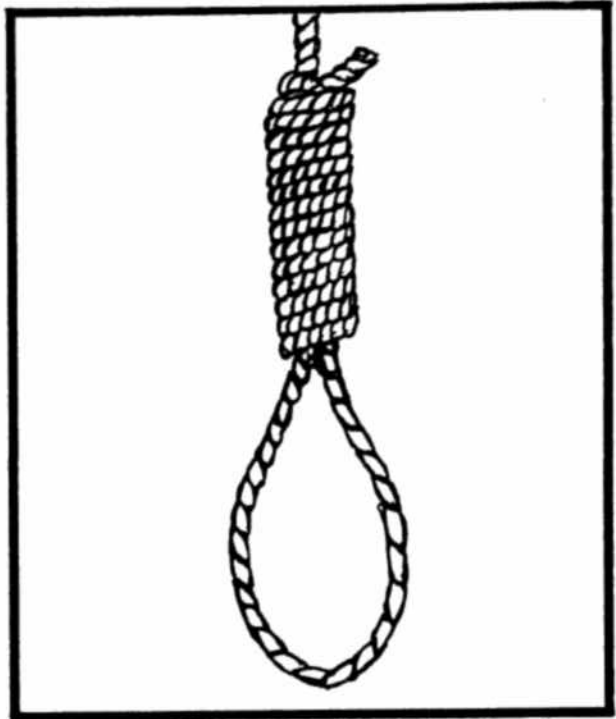

3



4

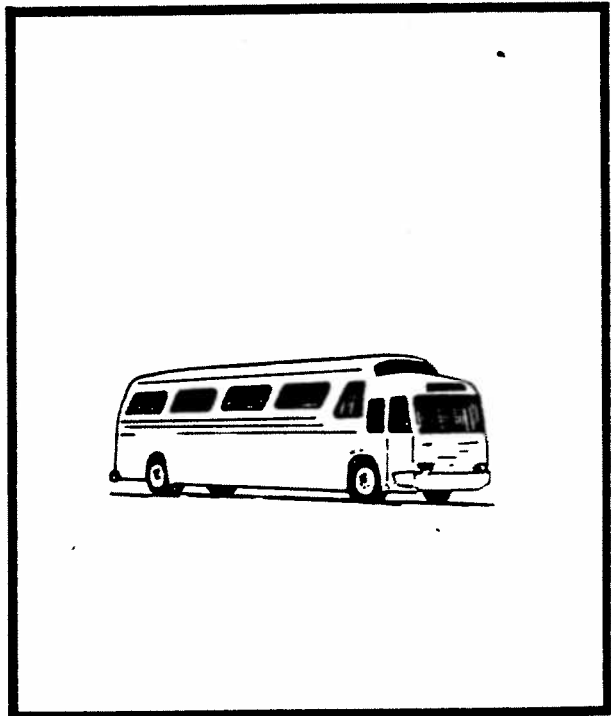

1

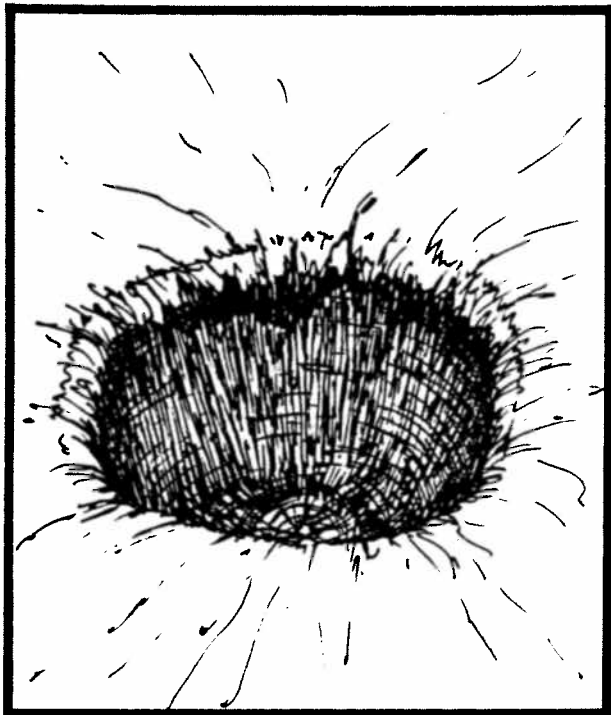

2

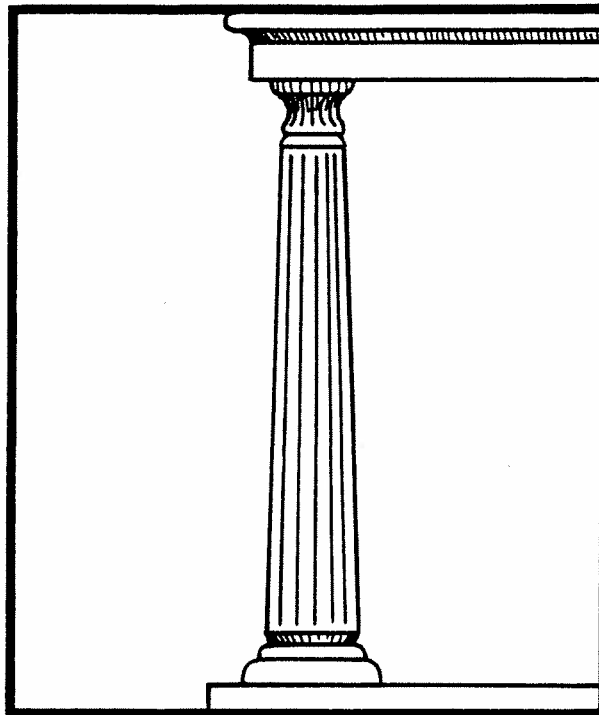

3

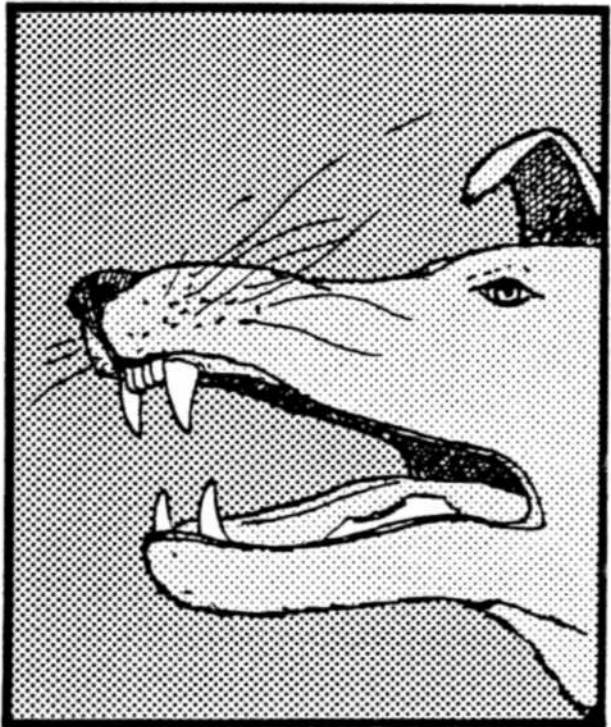

4

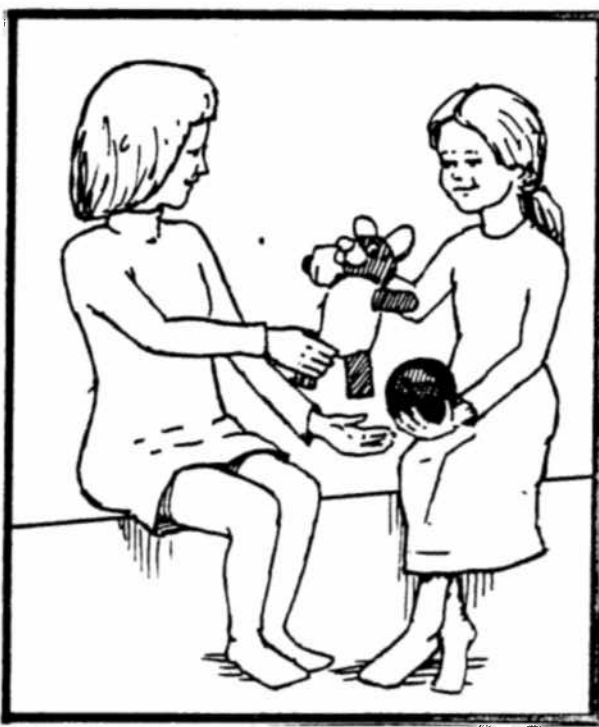

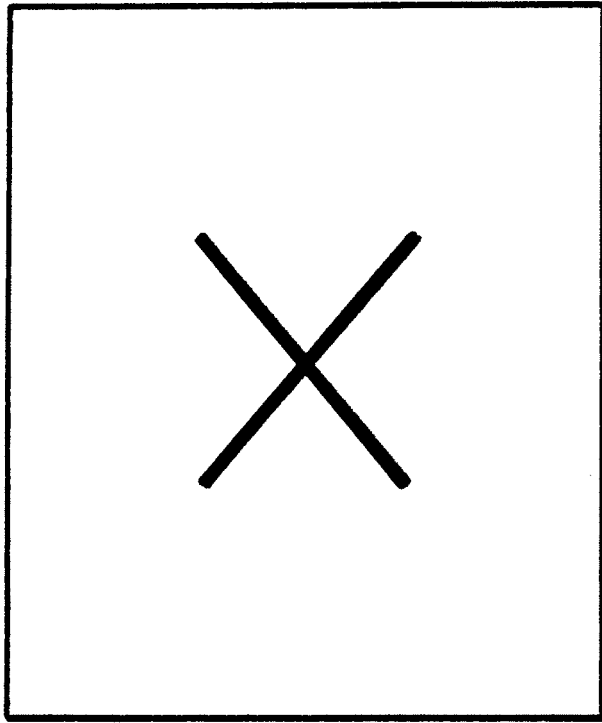

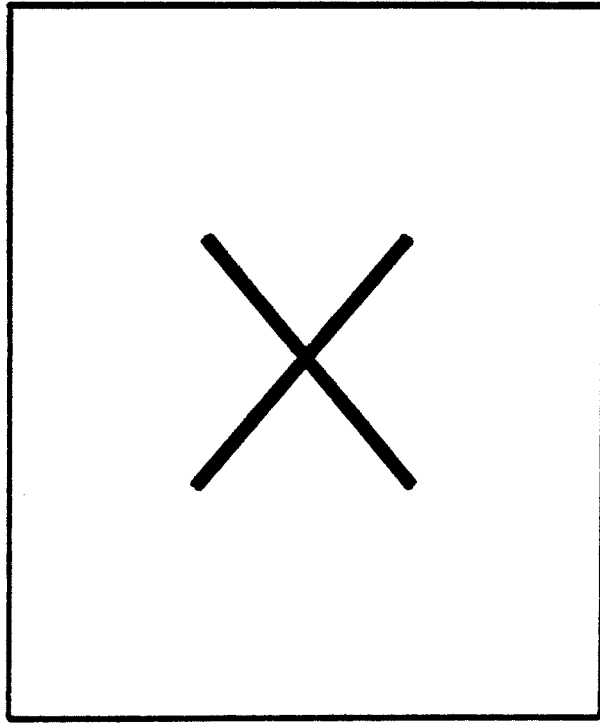

1

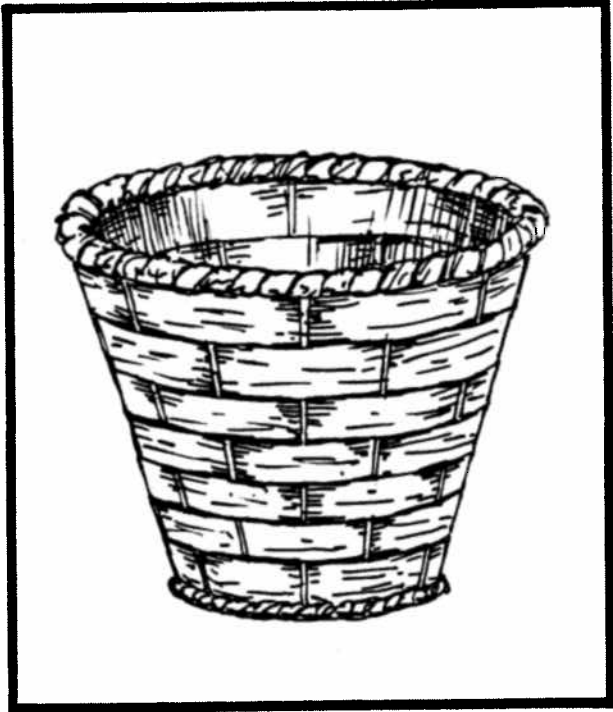

2

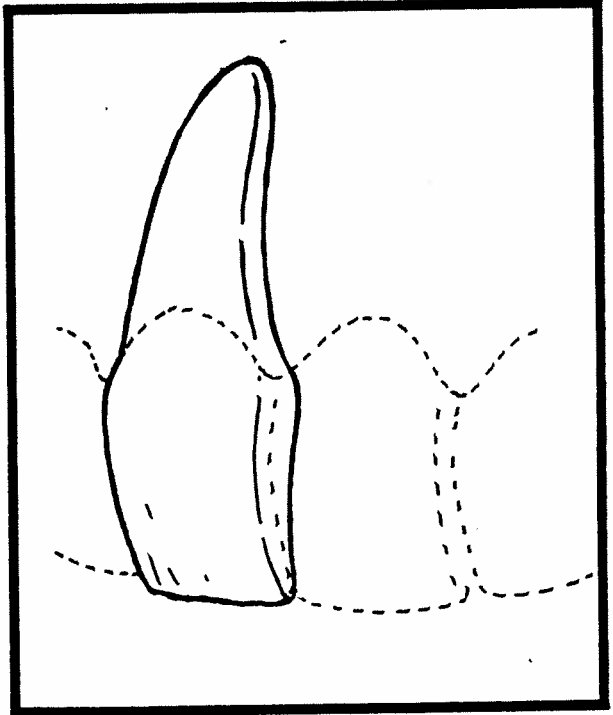

3

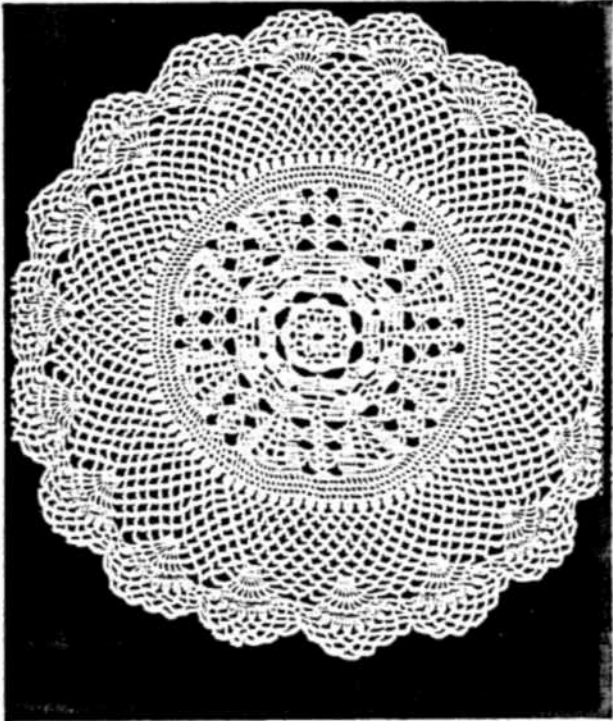

4



1

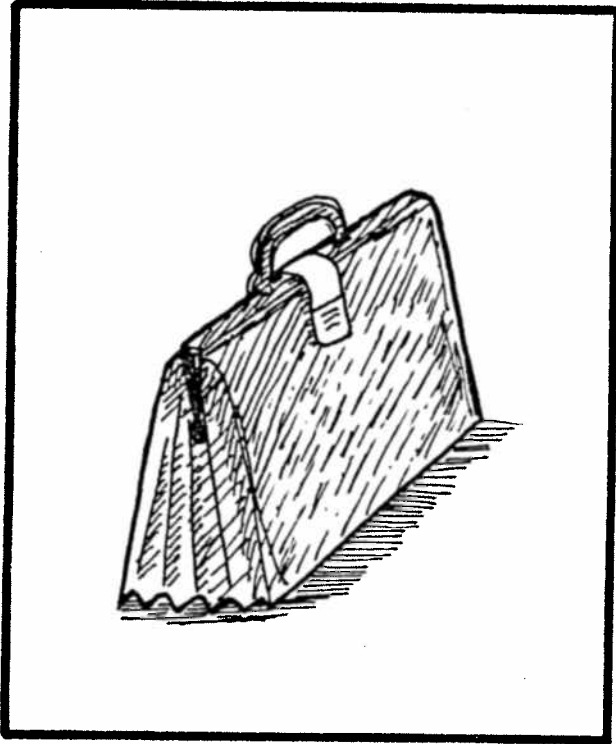

2

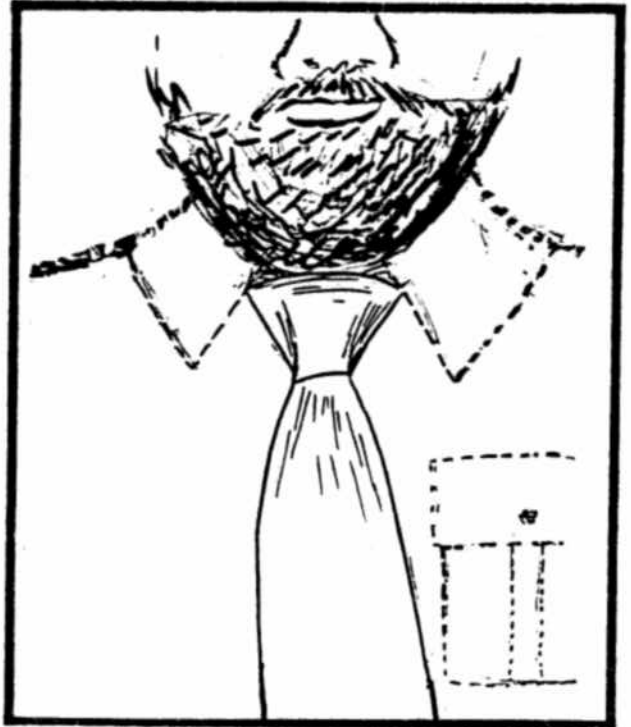

3

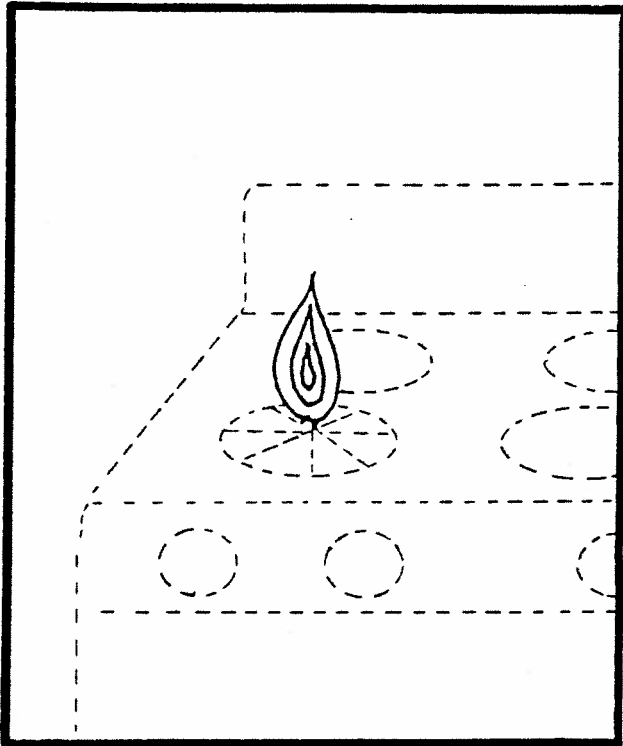

4

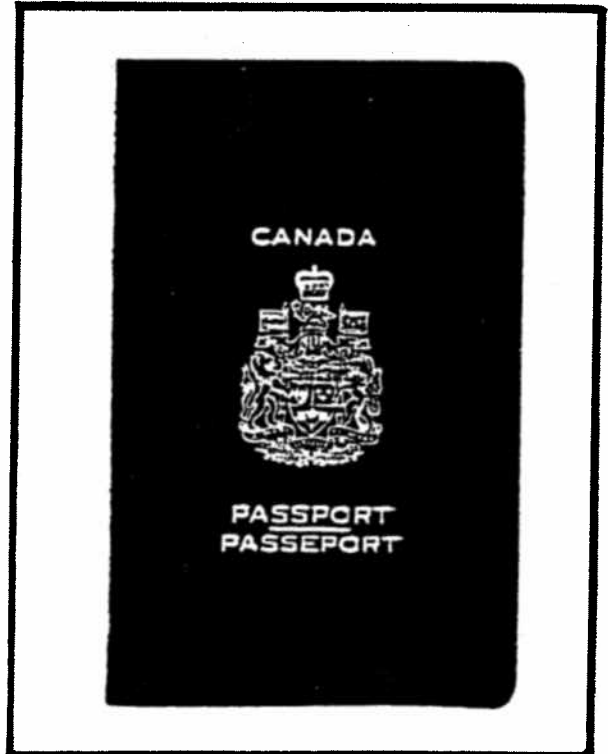

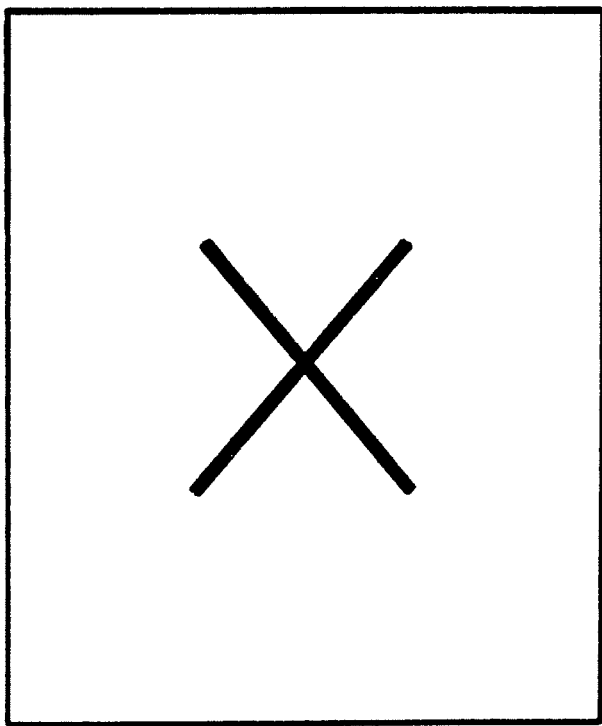

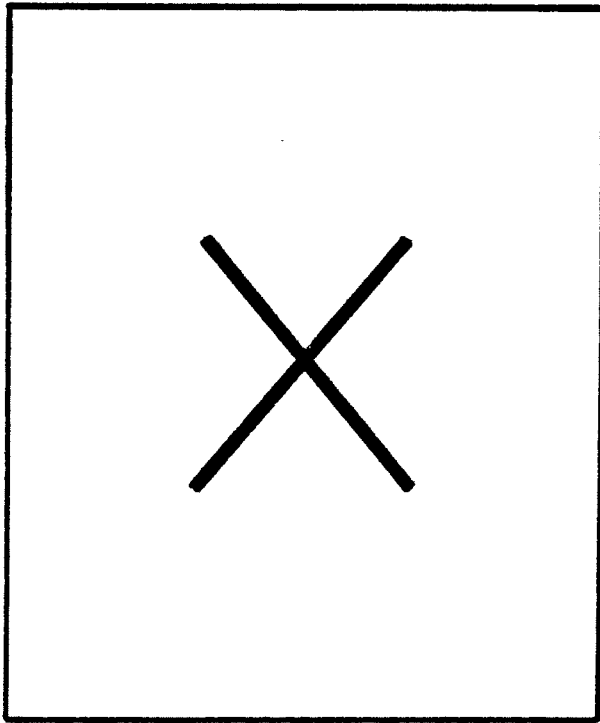

1

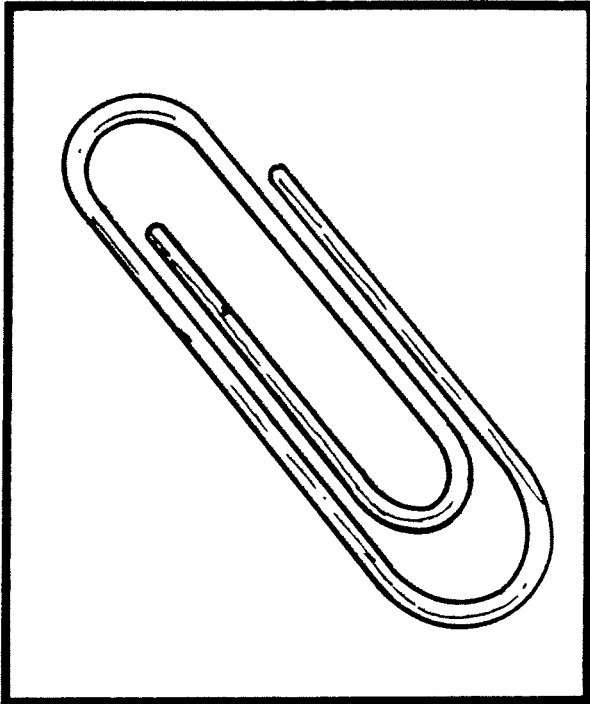

2

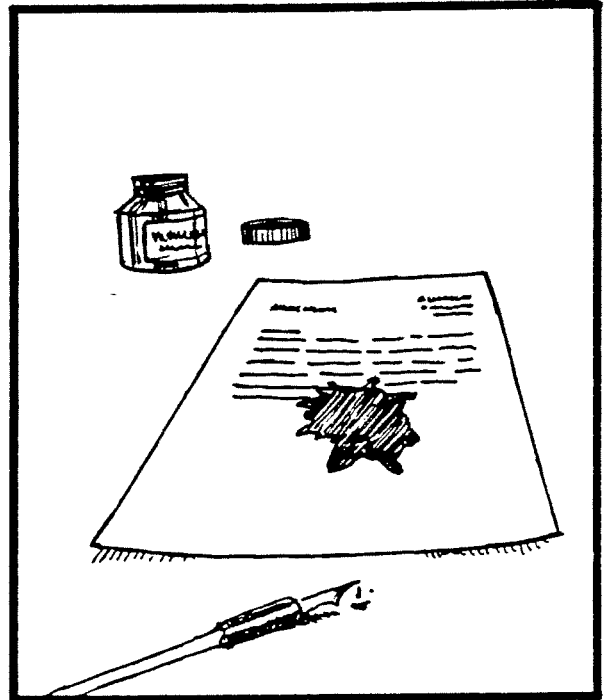

3

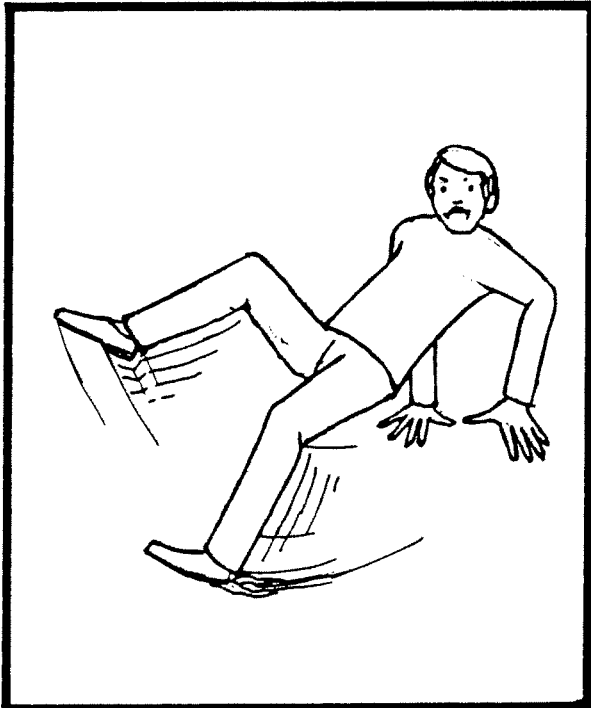

4

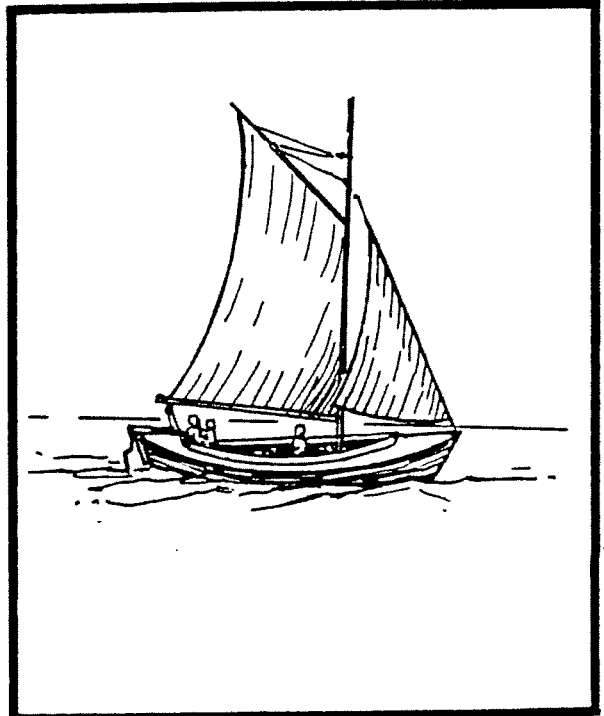

1

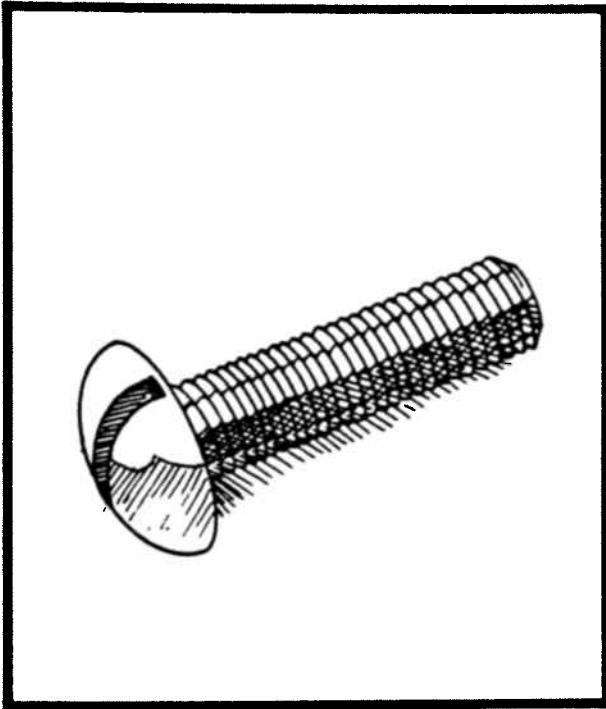

2

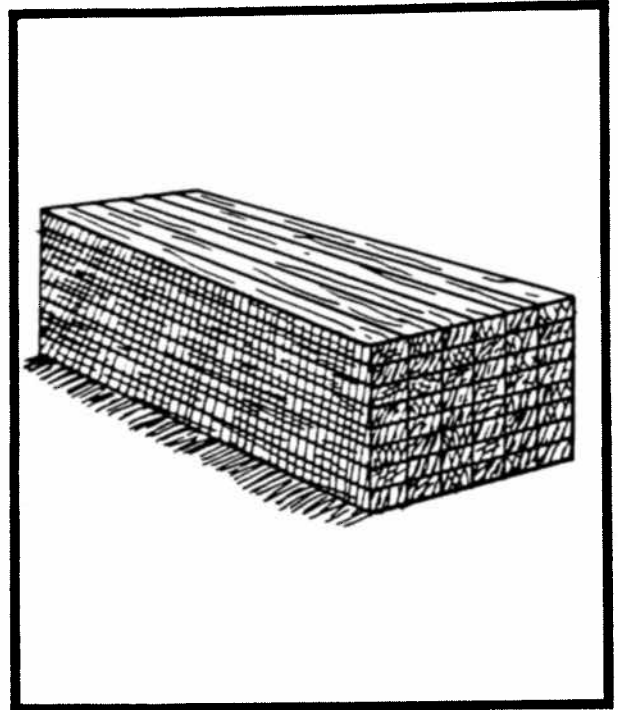

3

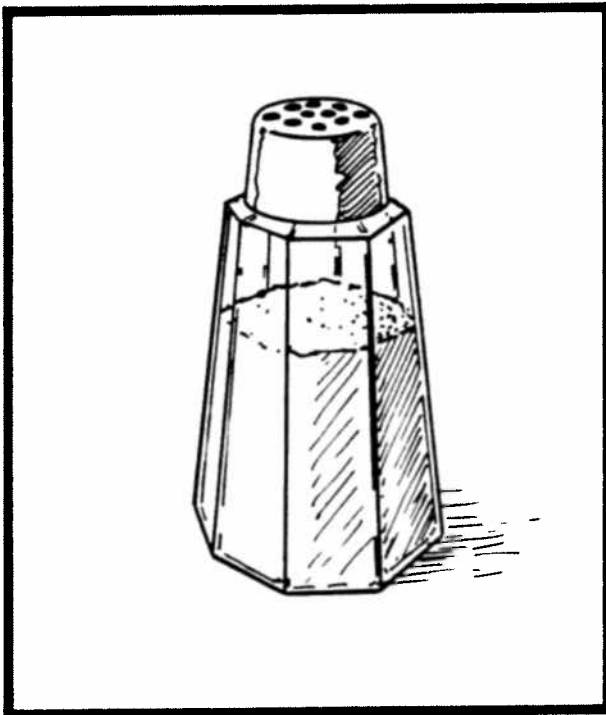

4



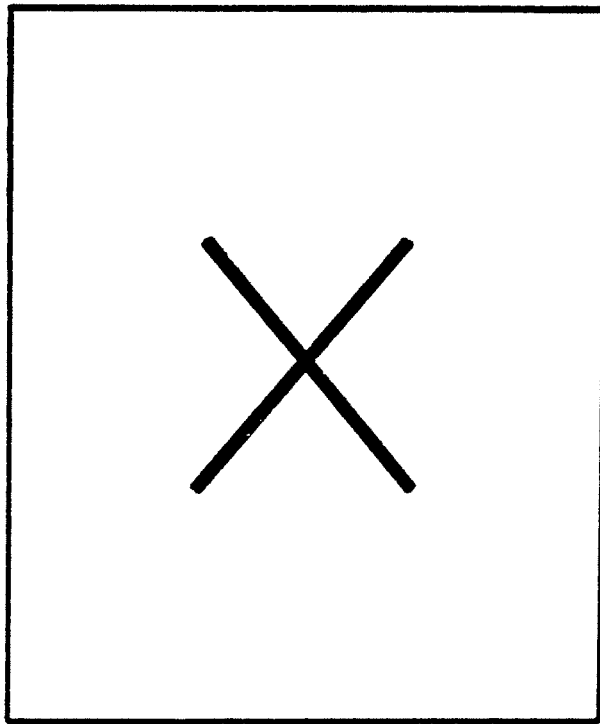

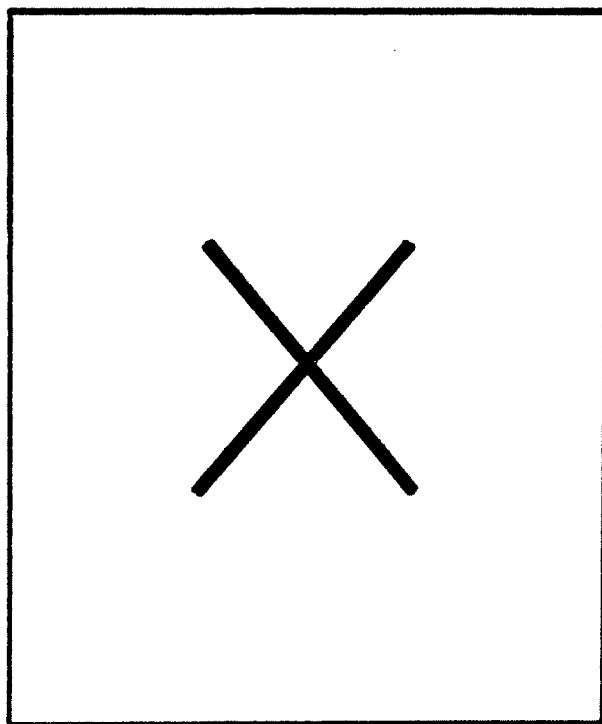

1

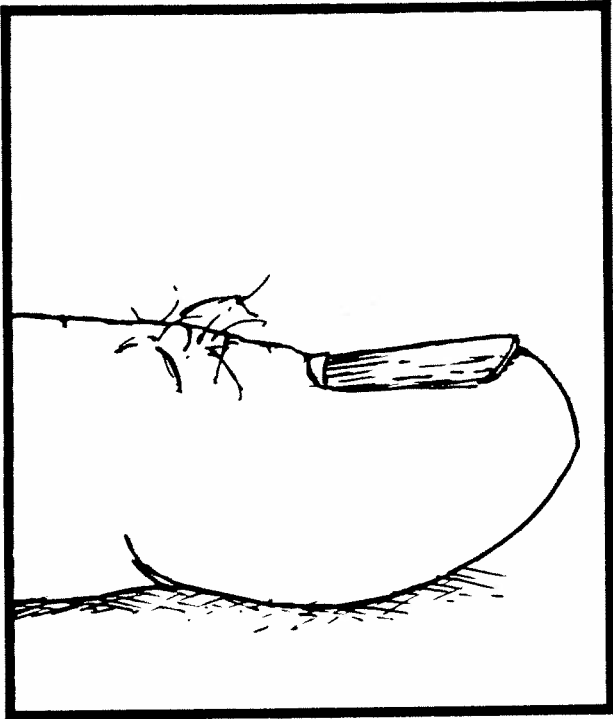

2

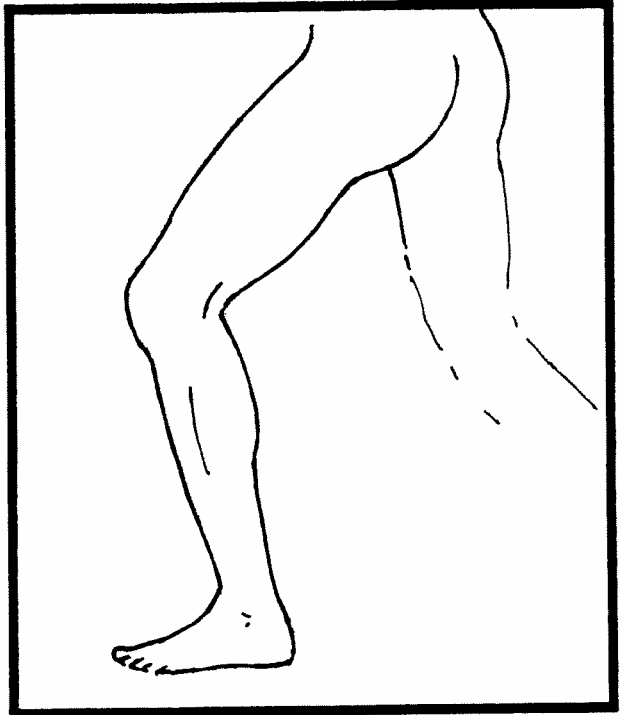

3

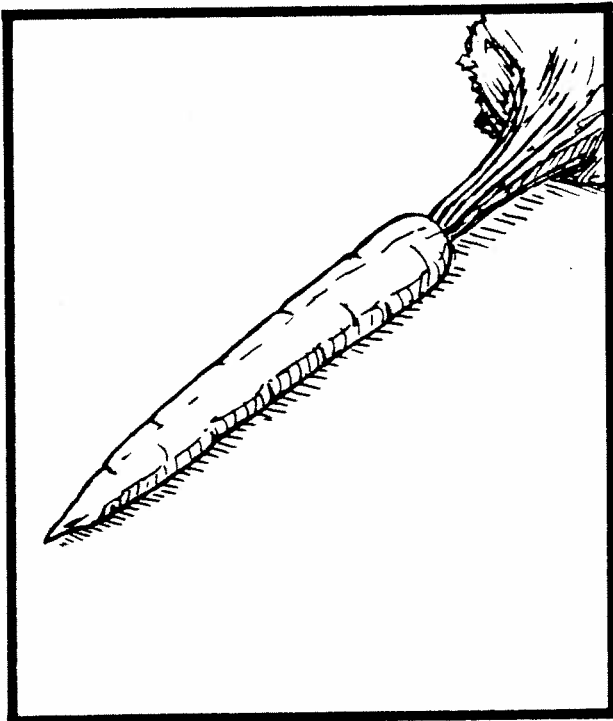

4



1

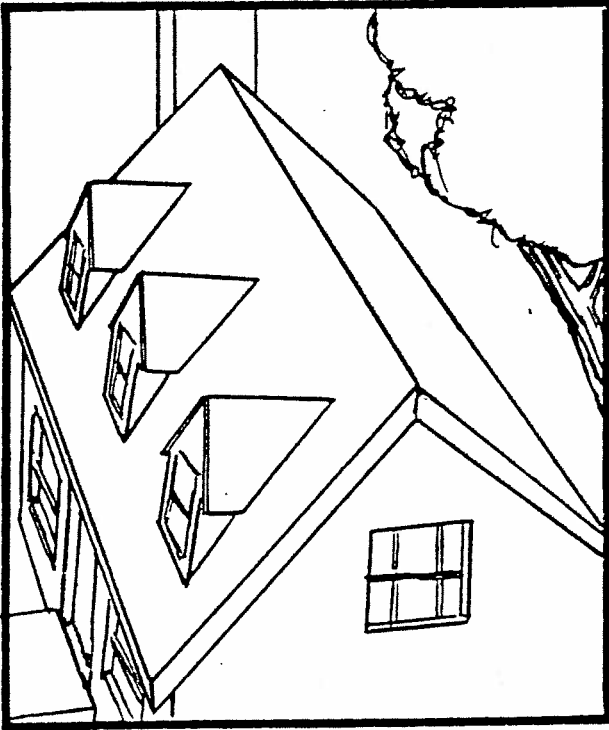

2

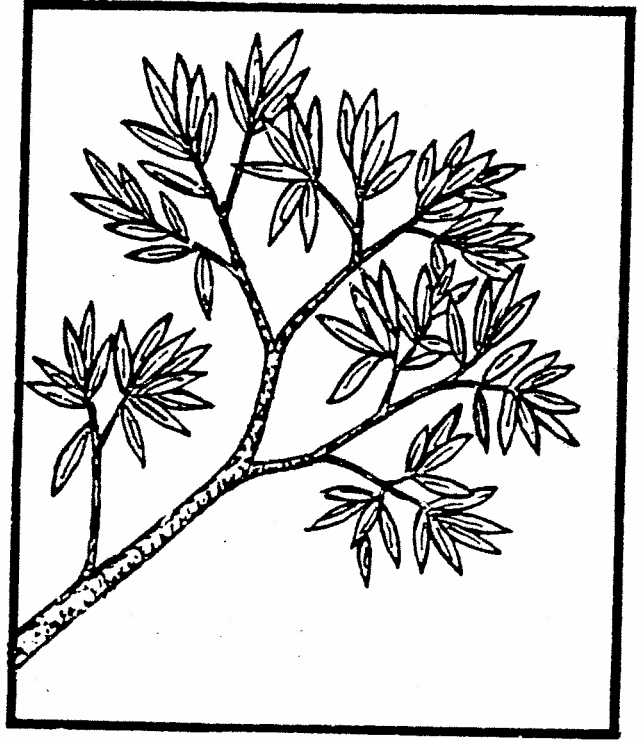

3

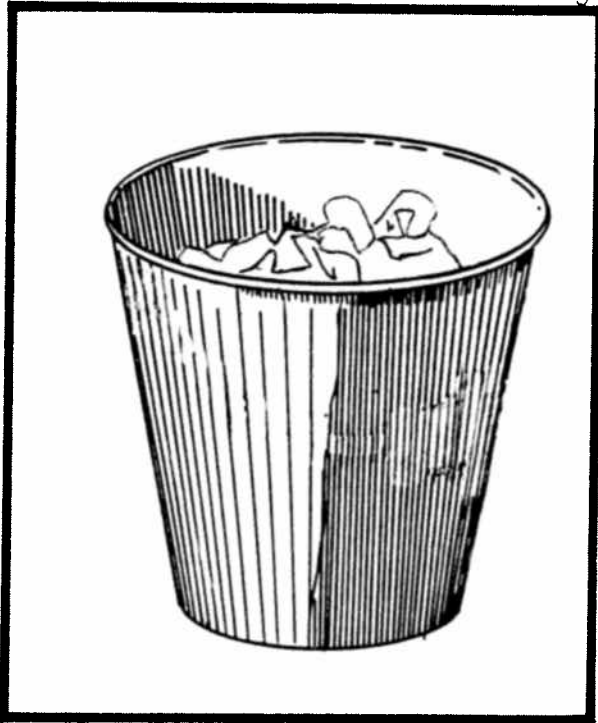

4

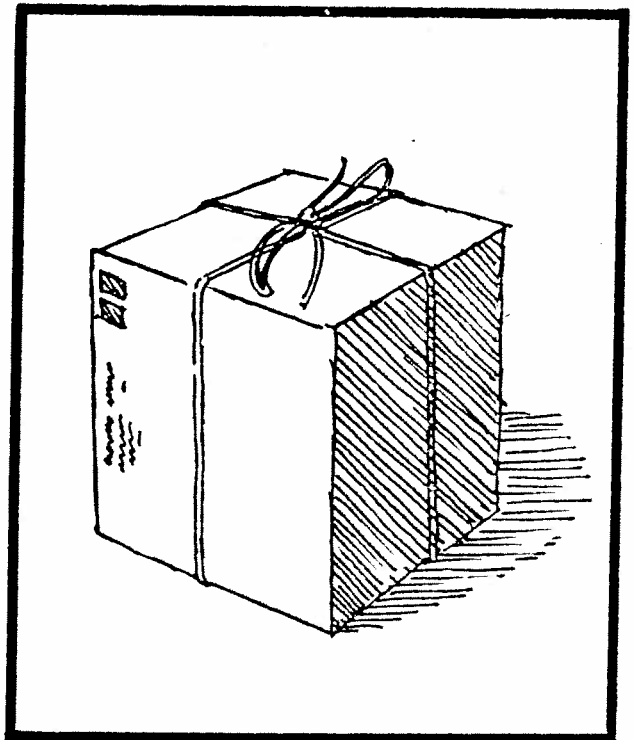

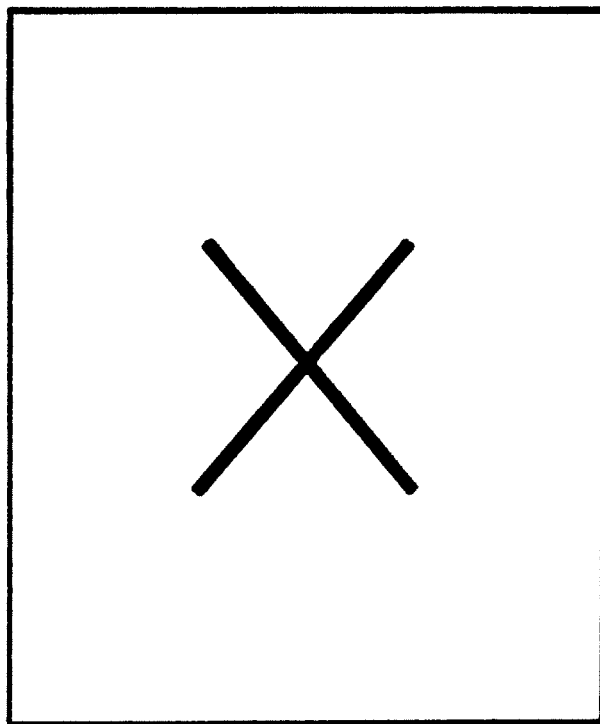

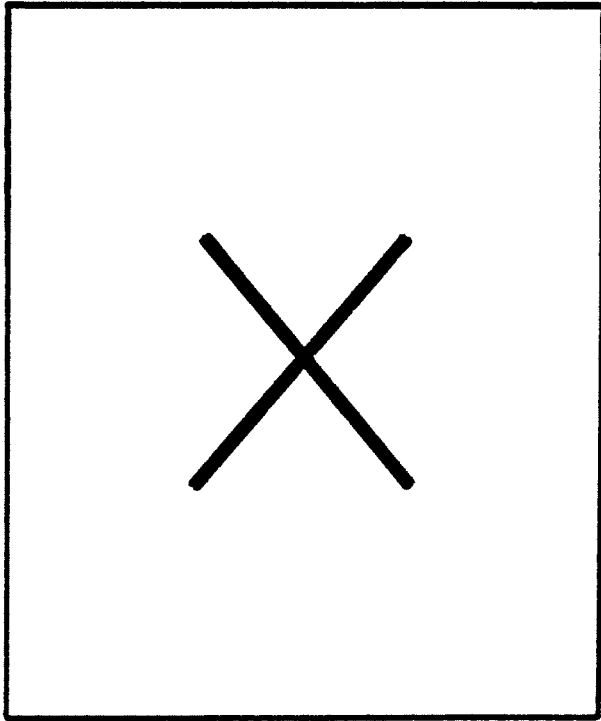

1

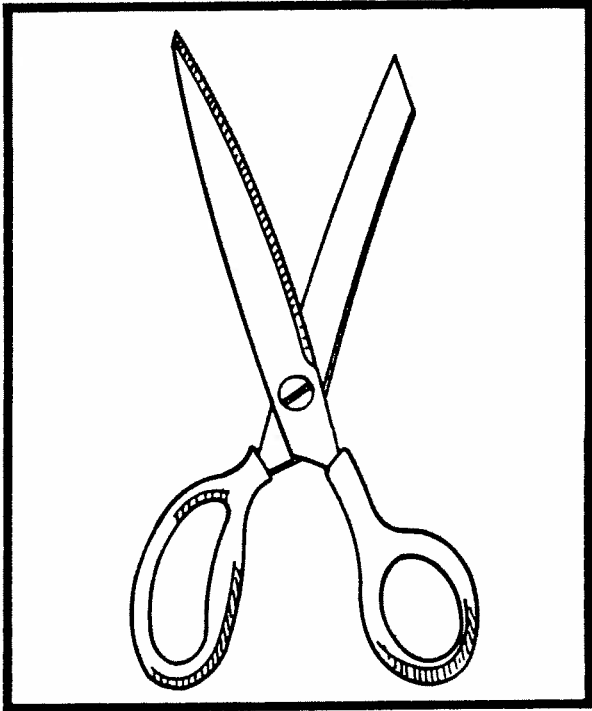

2

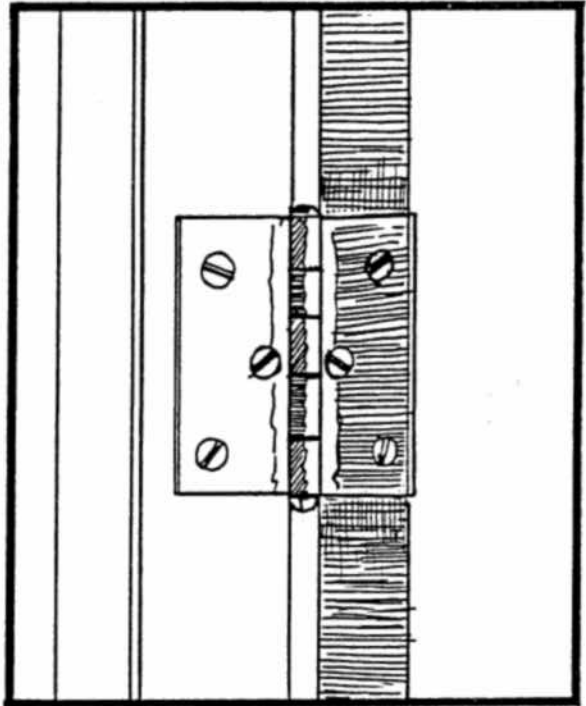

3

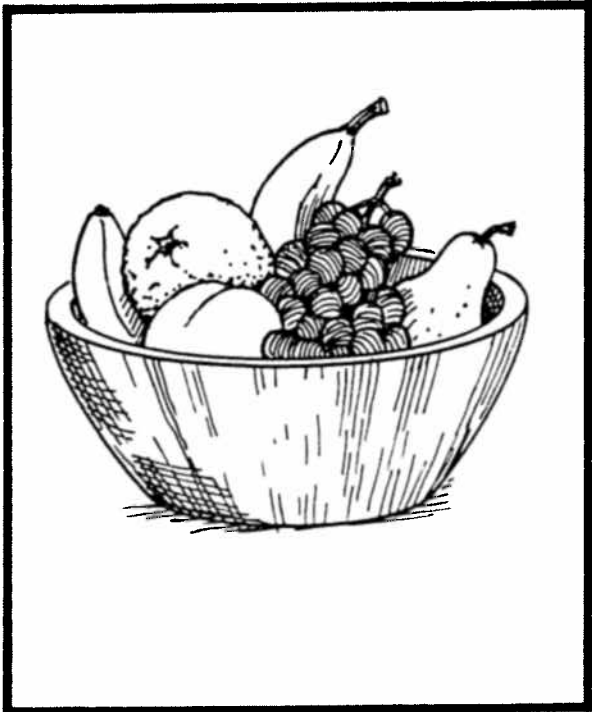

4

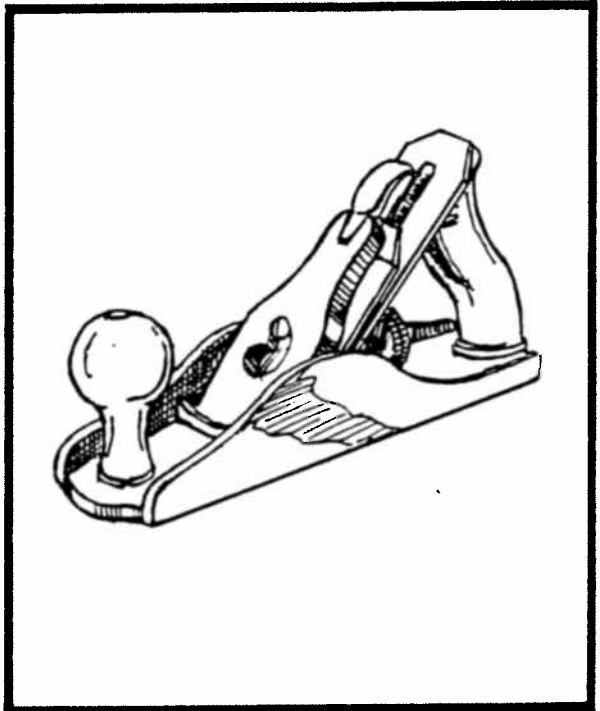

1

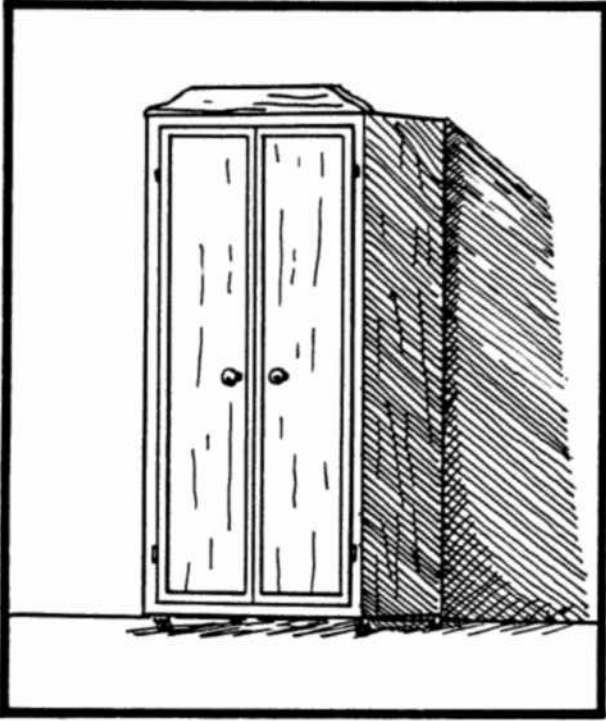

2

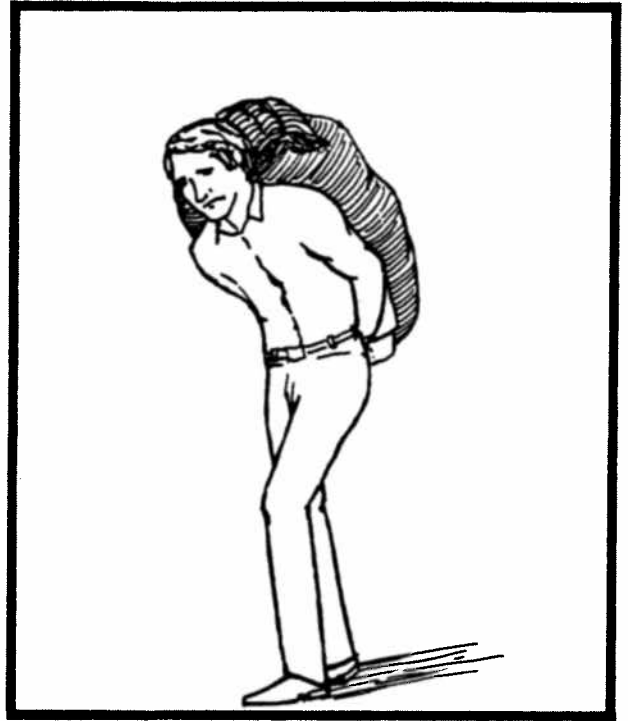

3

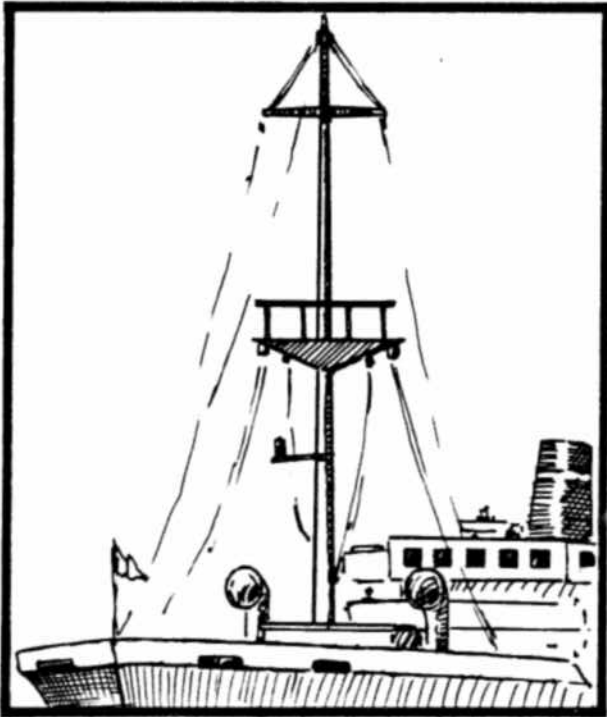

4



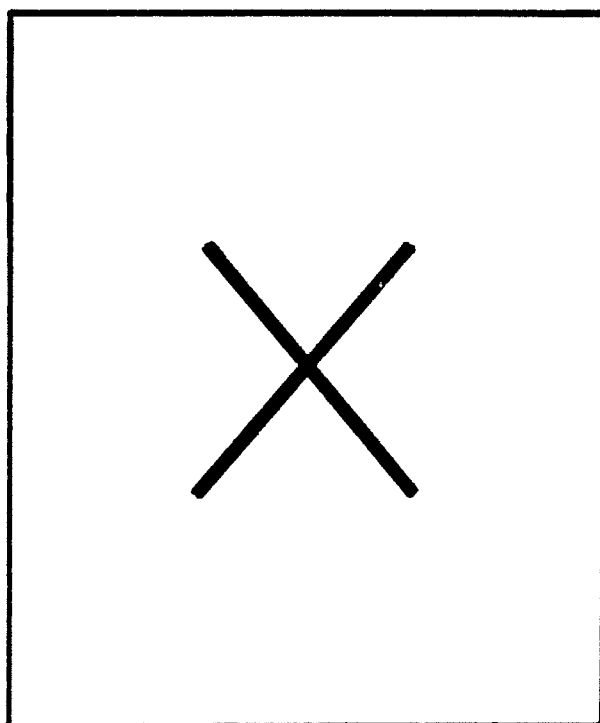

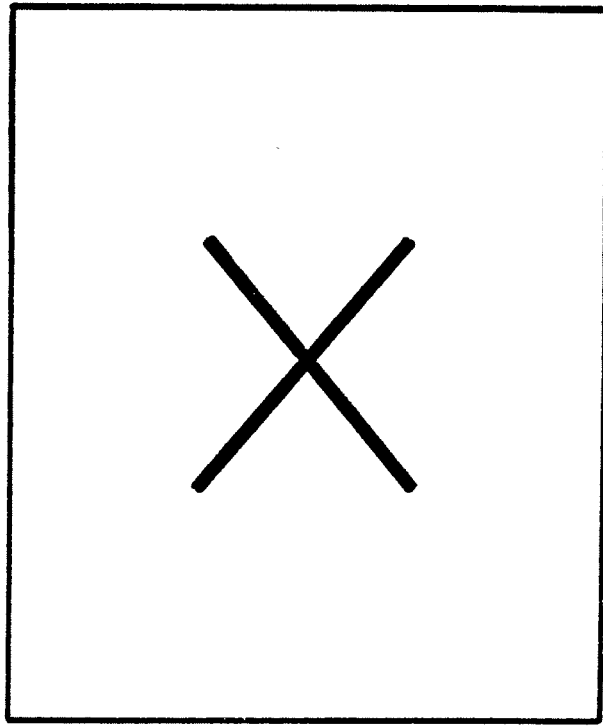

1

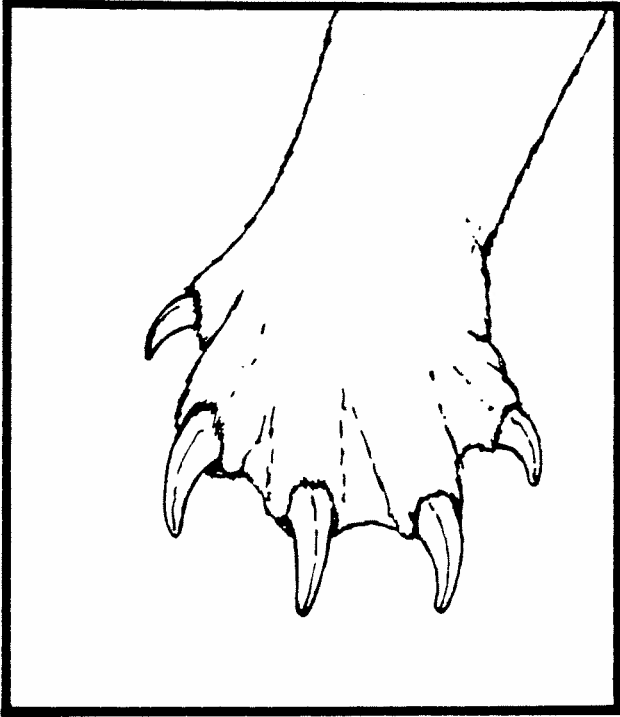

2

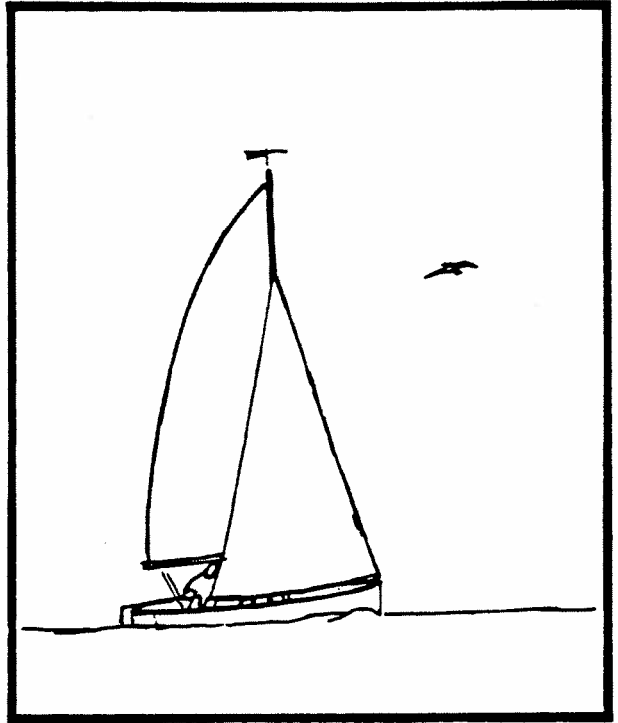

3

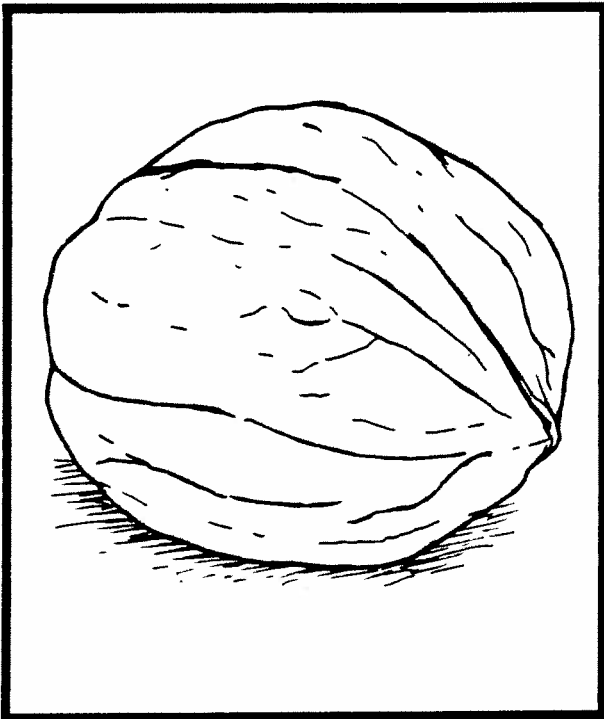

4

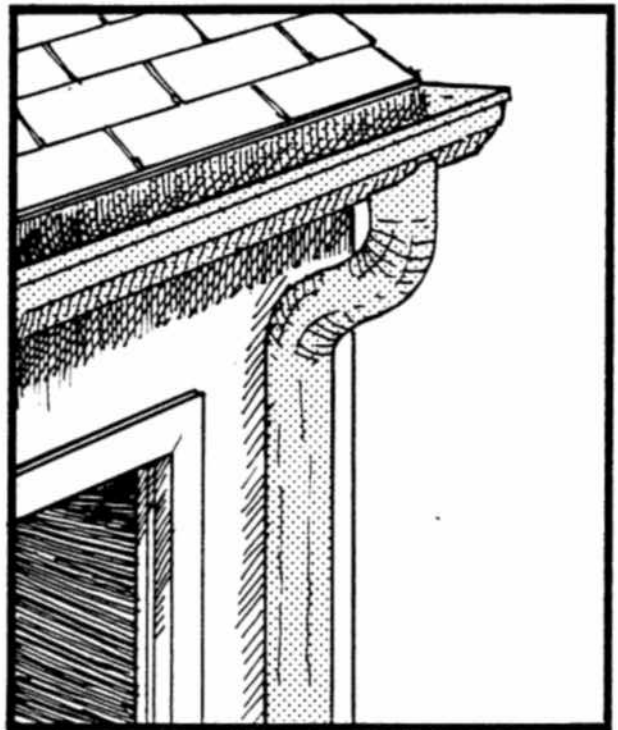

1

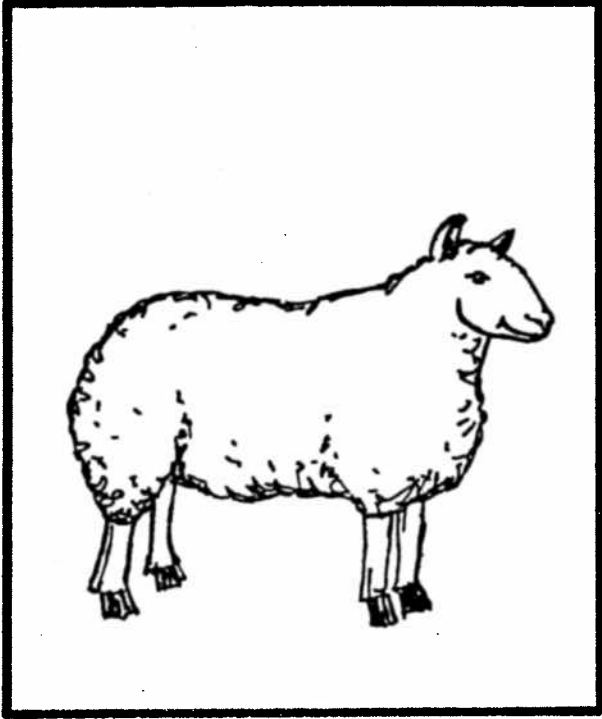

2



3

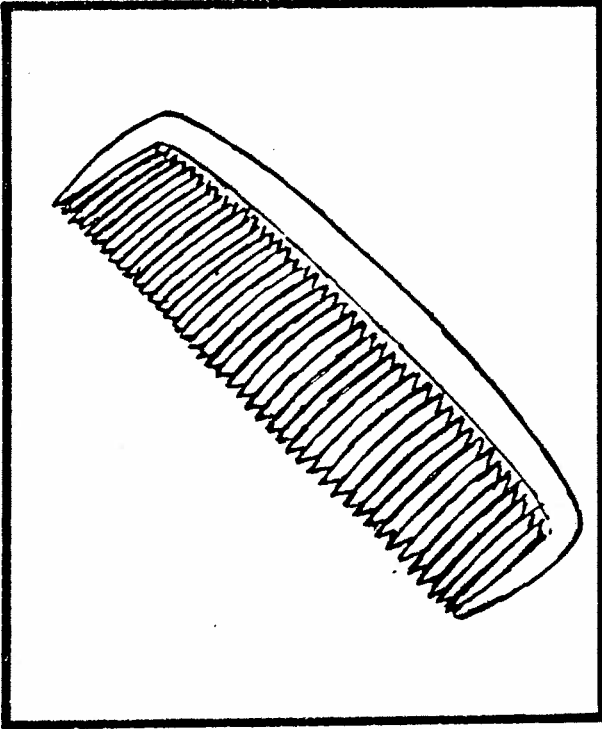

4

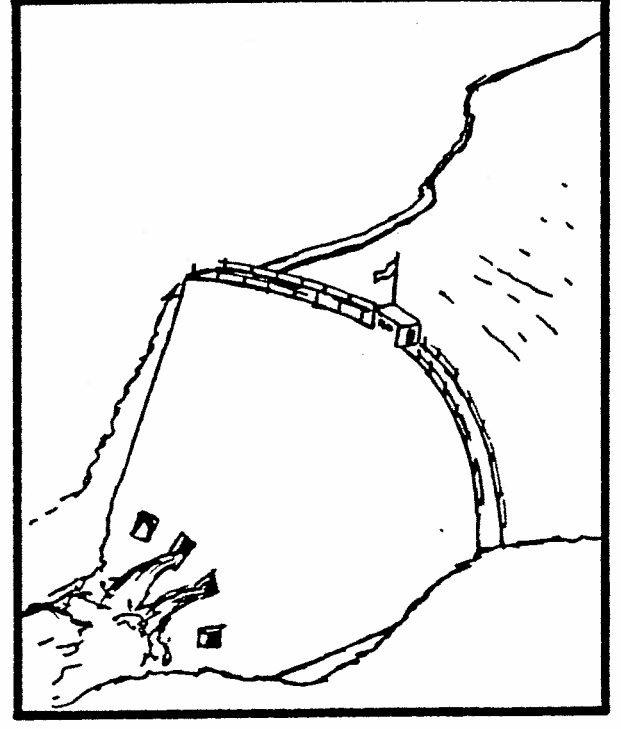

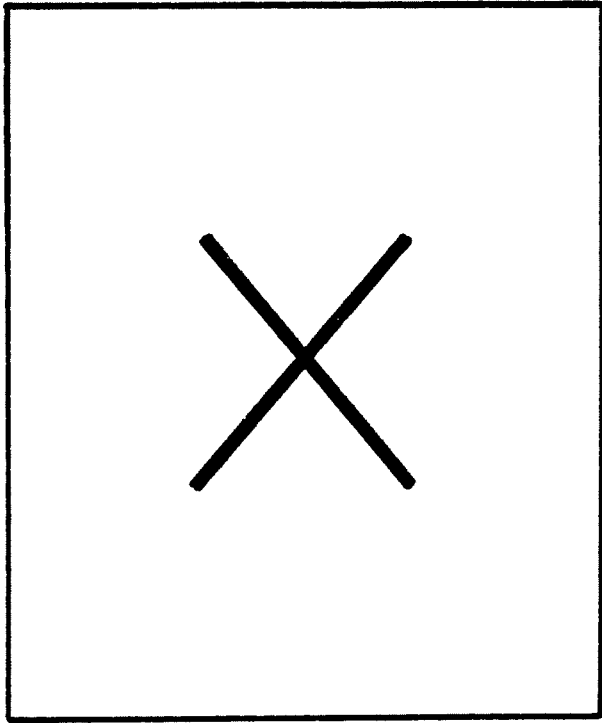

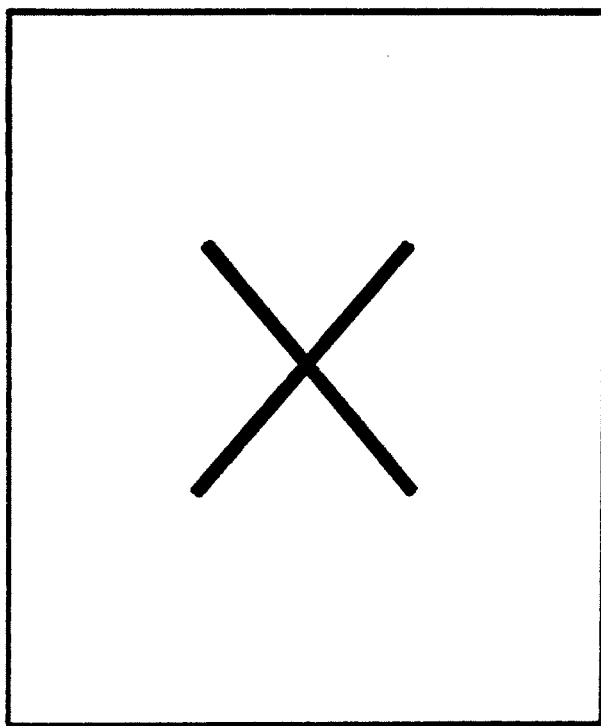

1

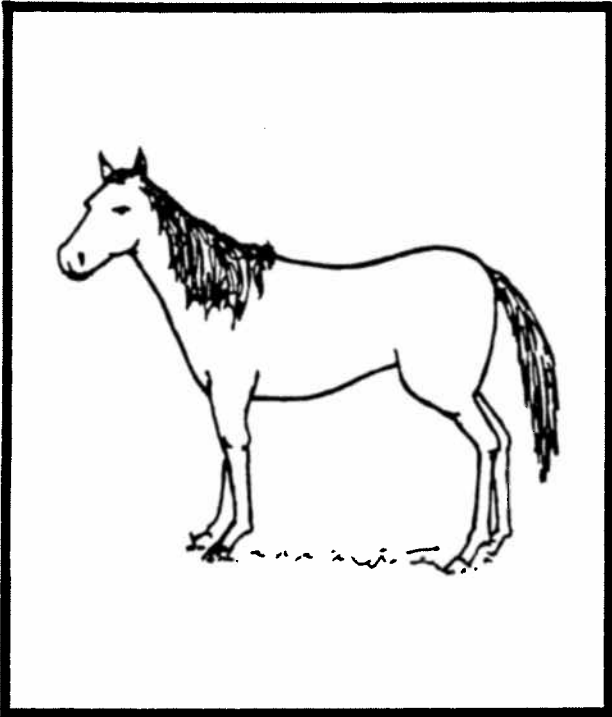

2

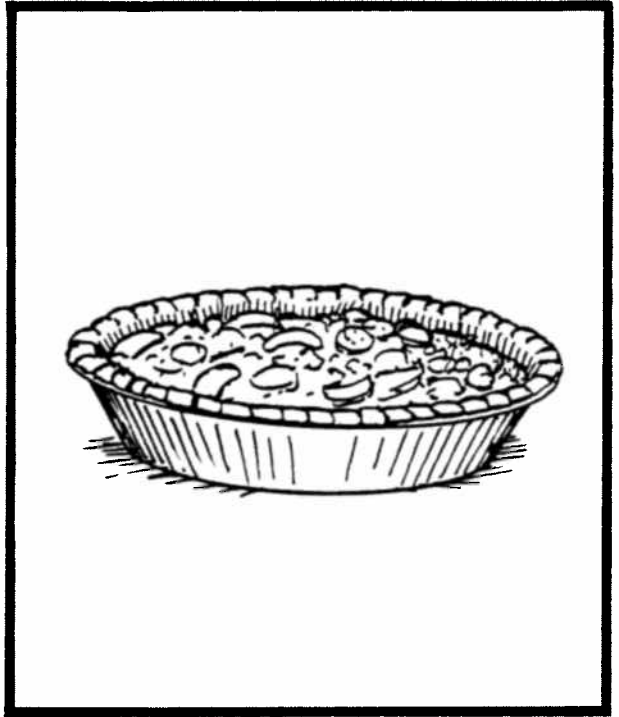

3

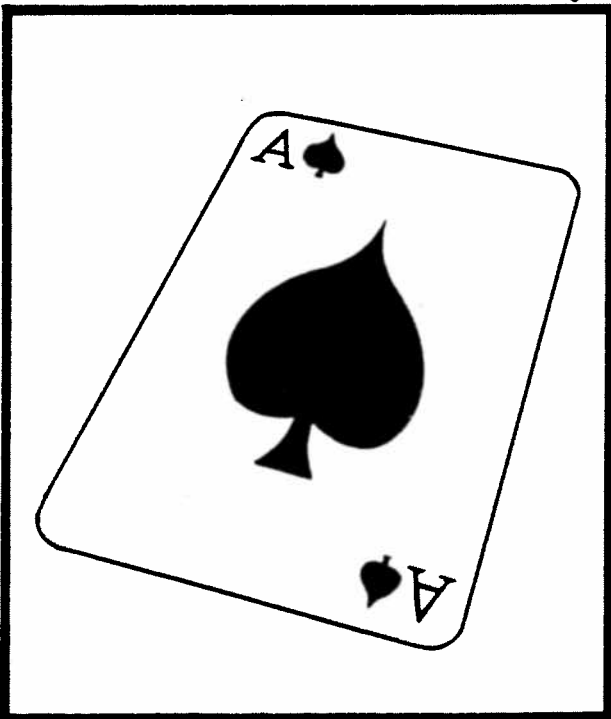

4

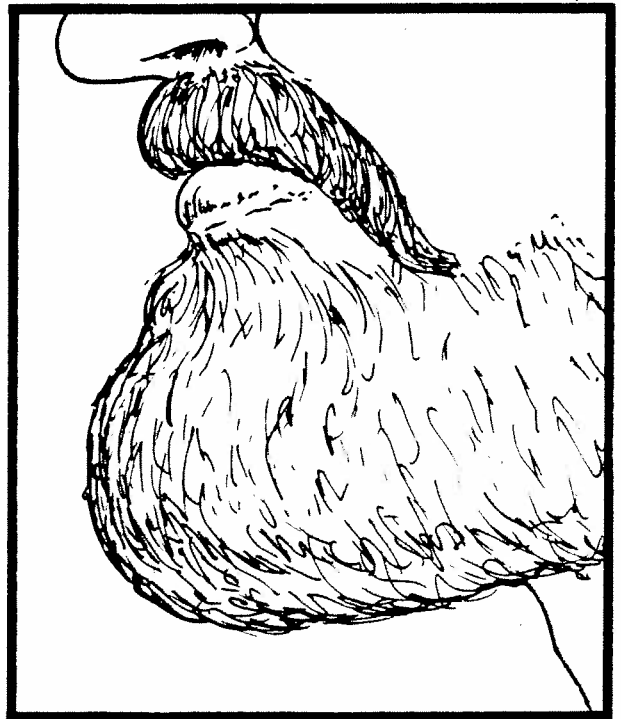

SYNTACTISCH BEGRIPSVERMOGEN

1

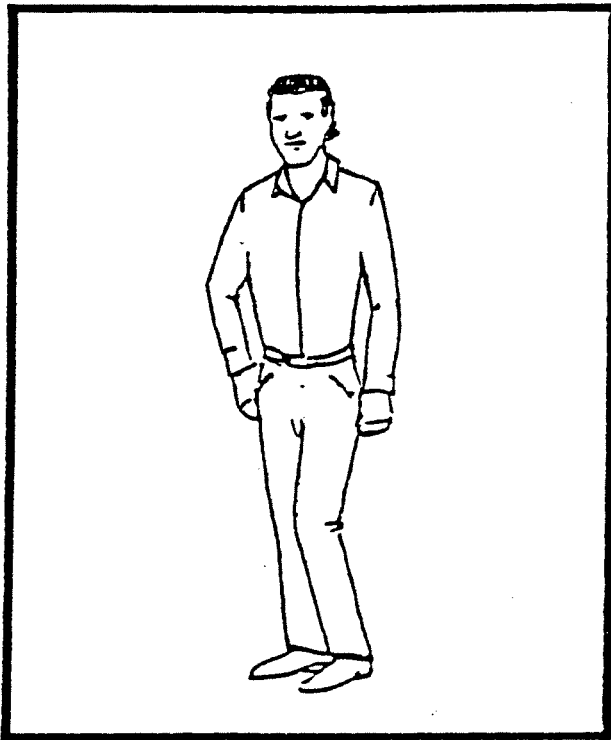

2

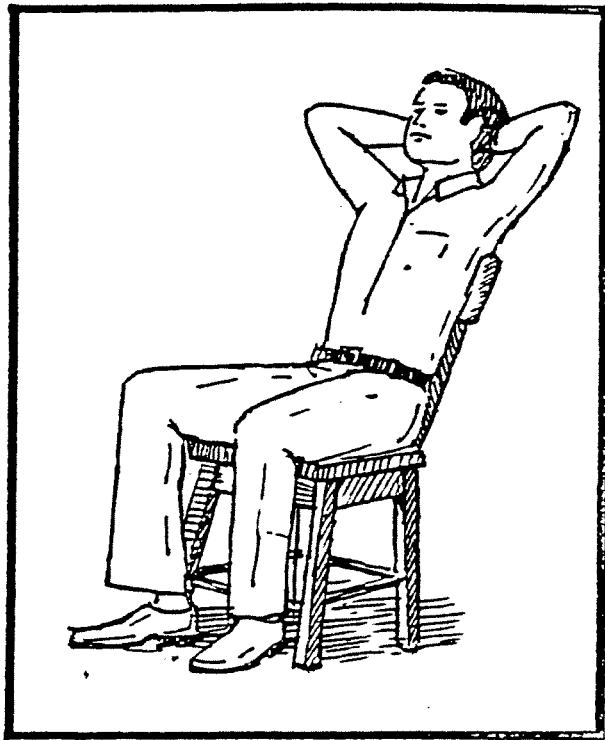

3

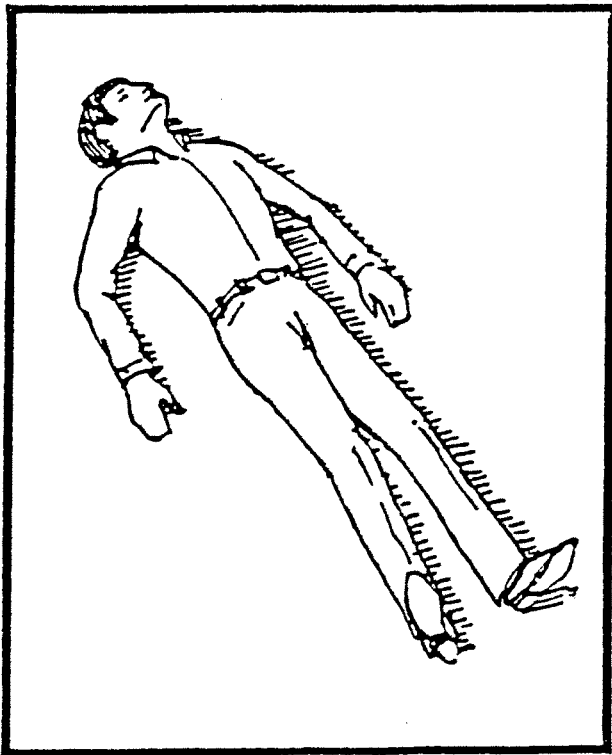

4



1

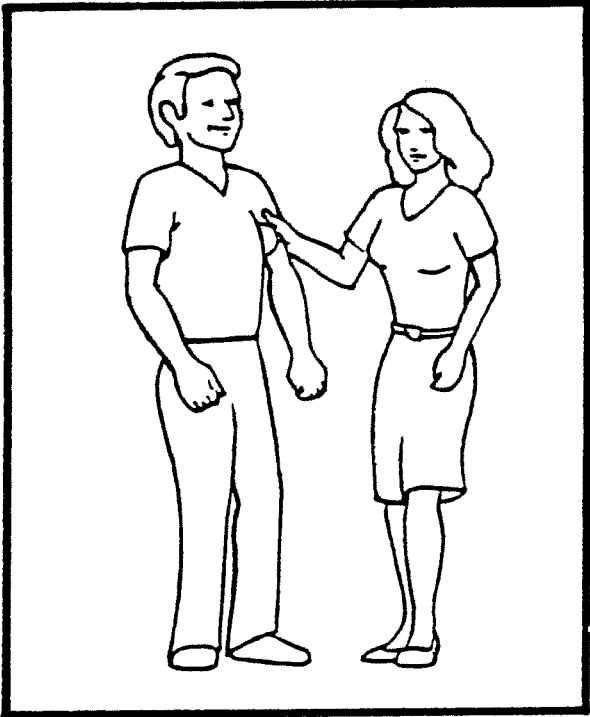

2

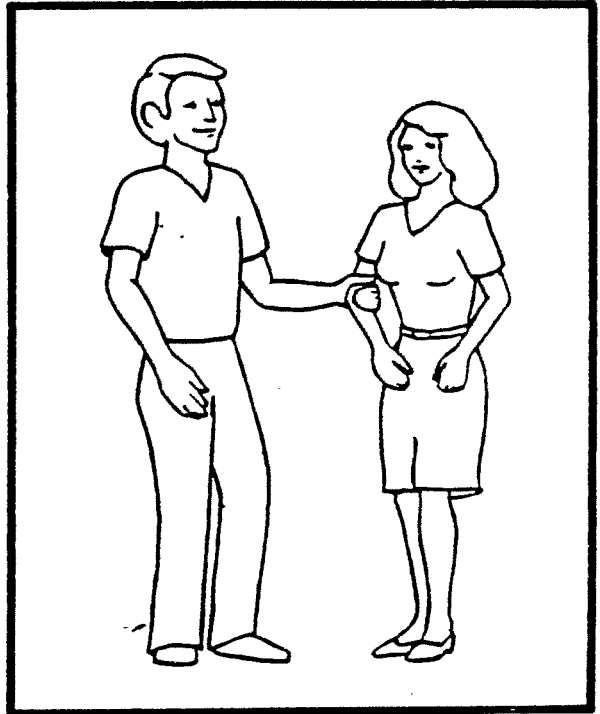

3

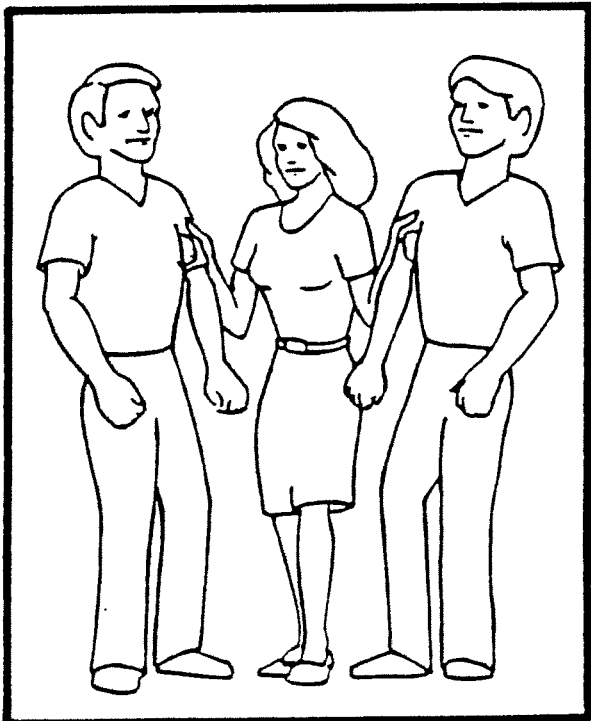

4

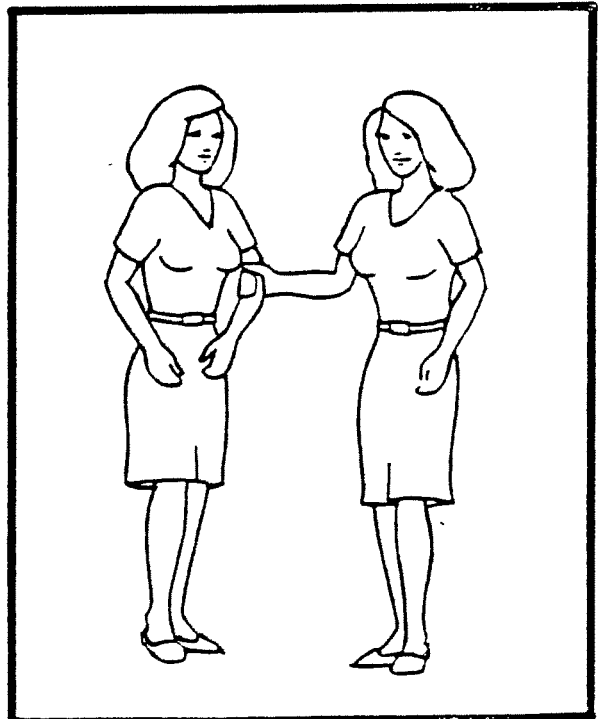

1

1



2



3

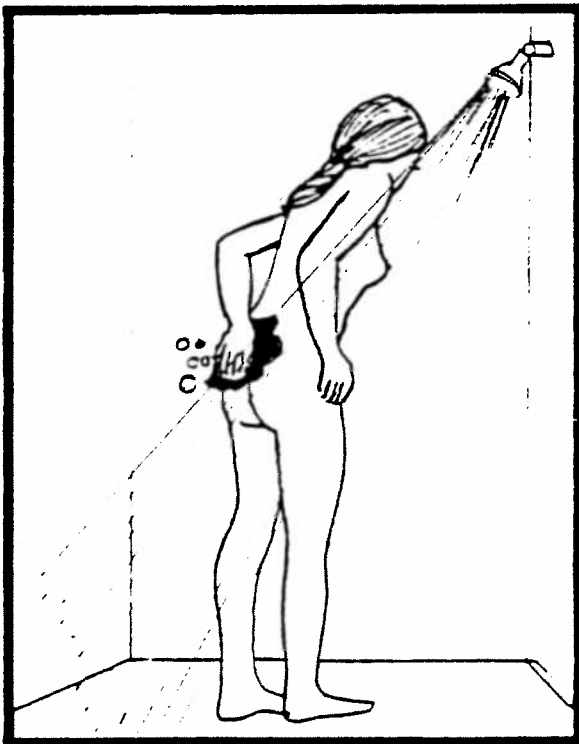

4

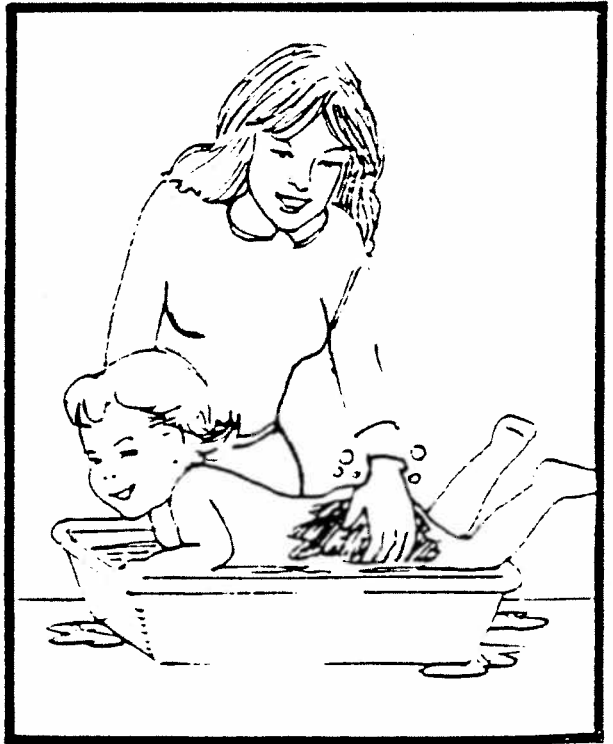

2

1

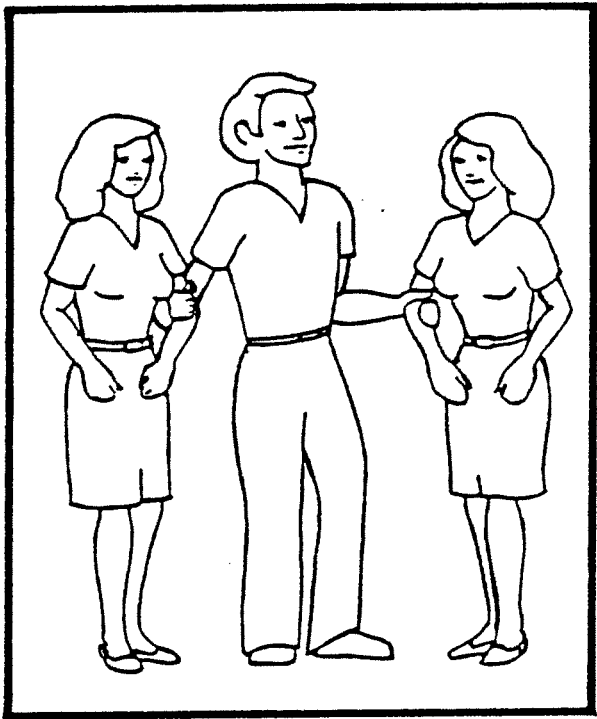

2

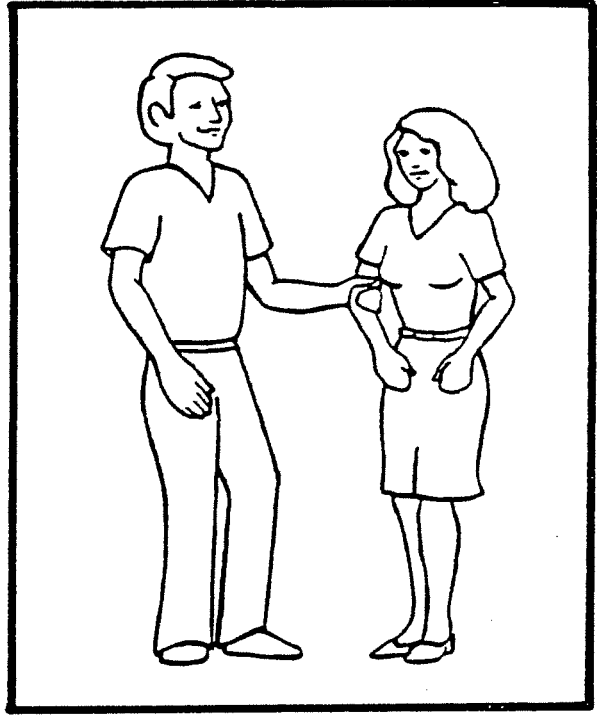

3

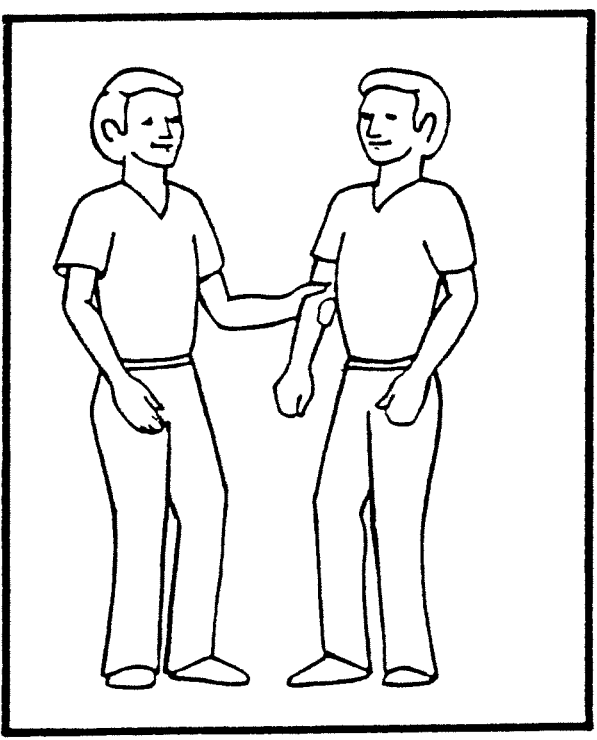

4

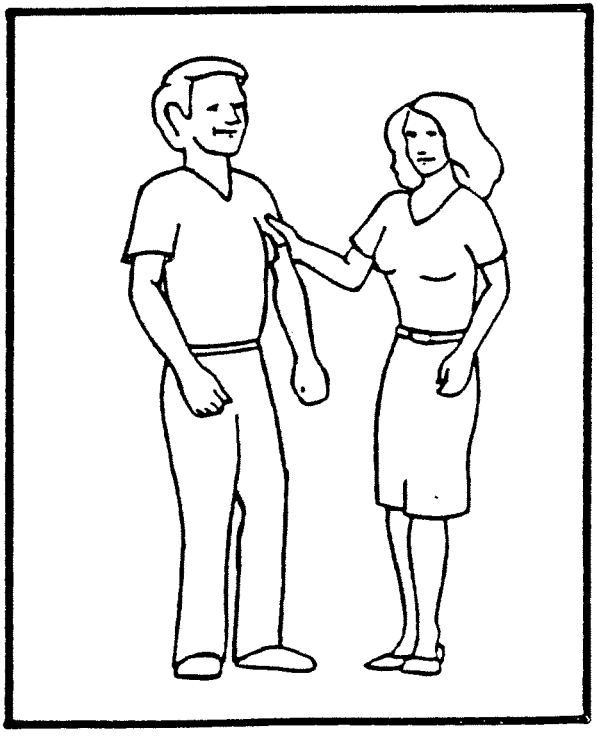

3

1

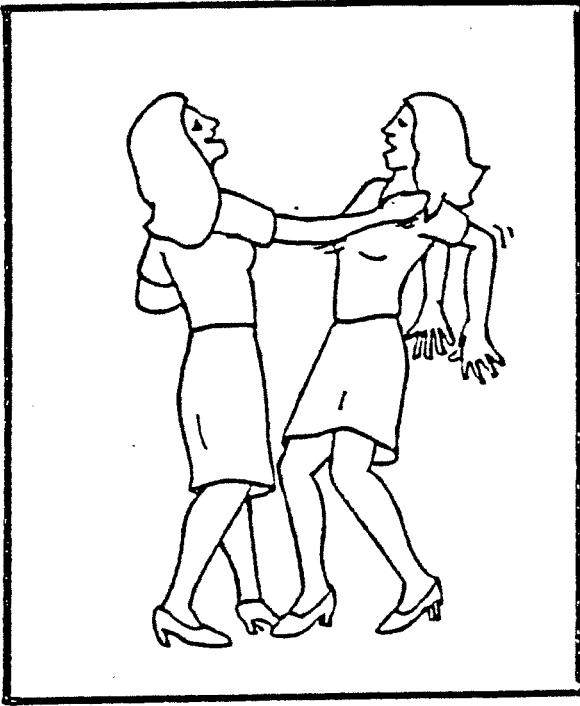

2

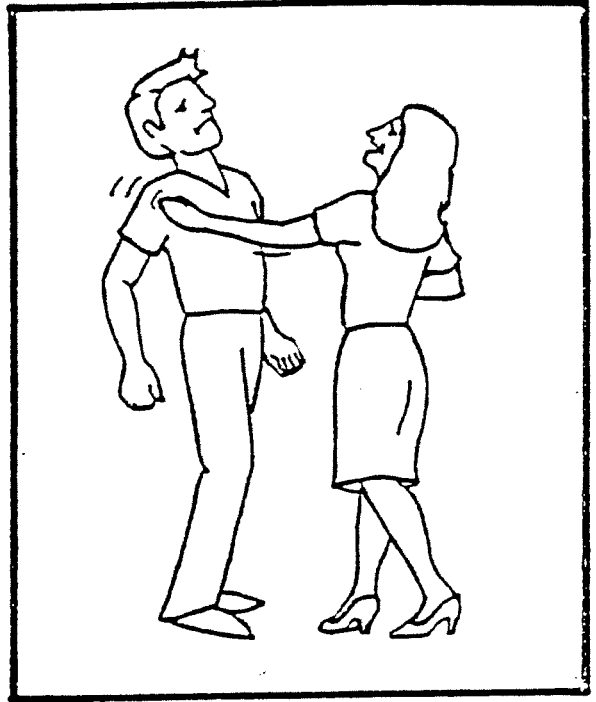

3

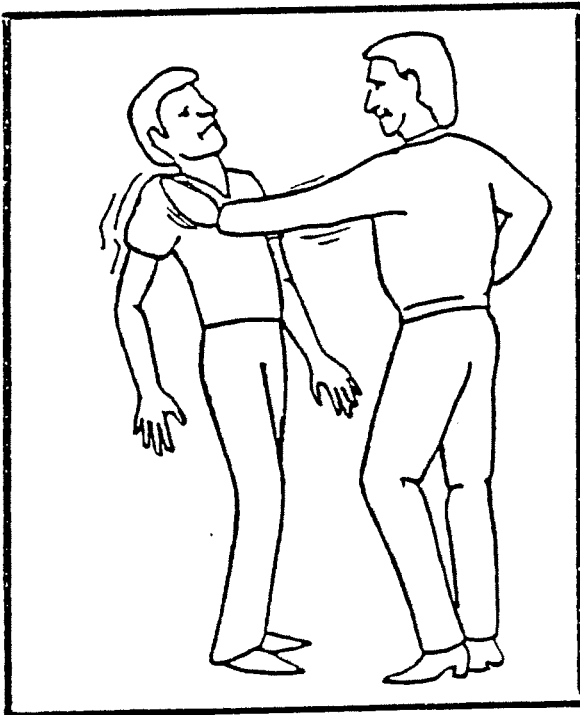

4

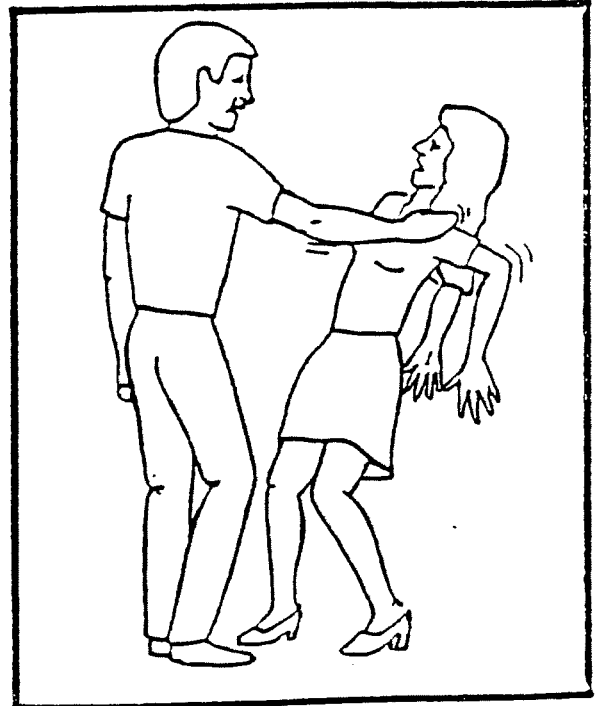

4

1

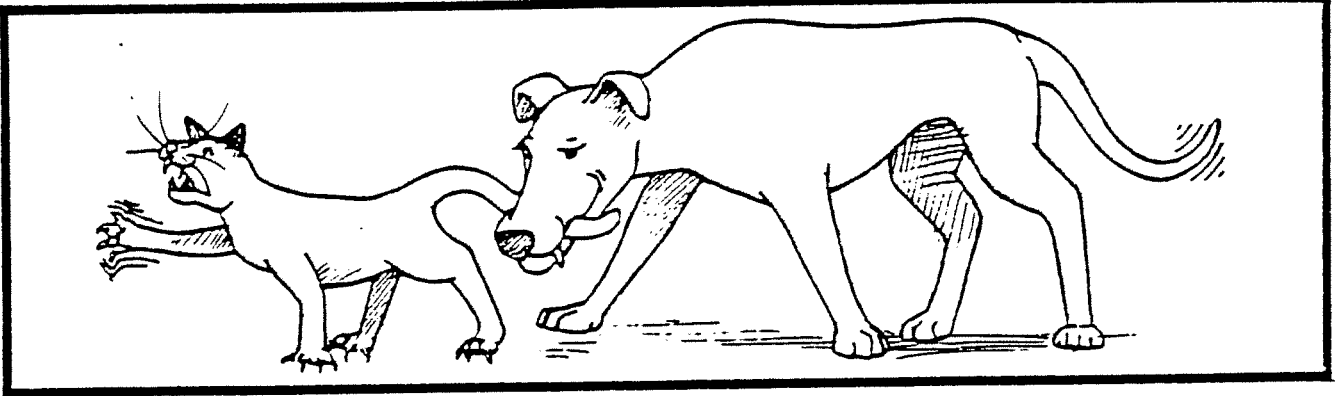

2

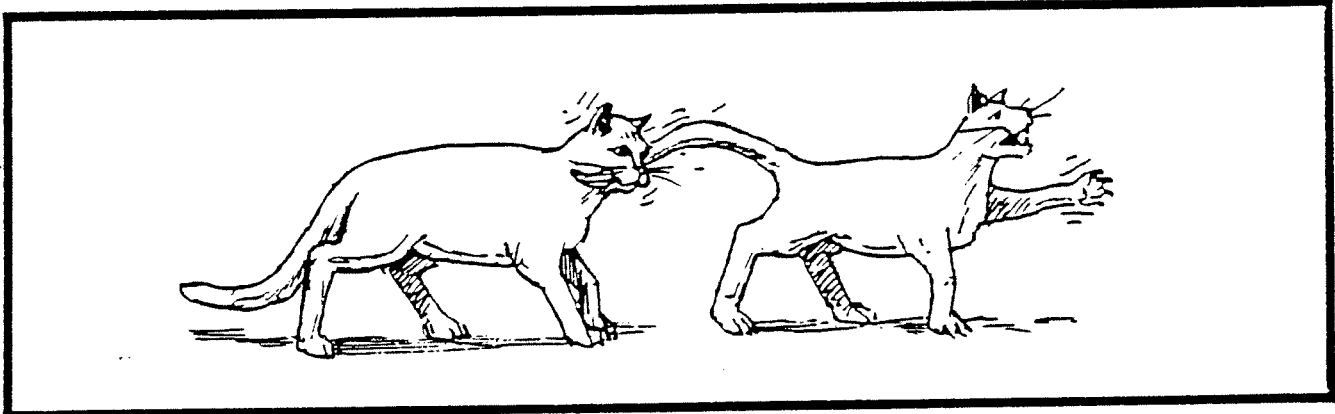

3

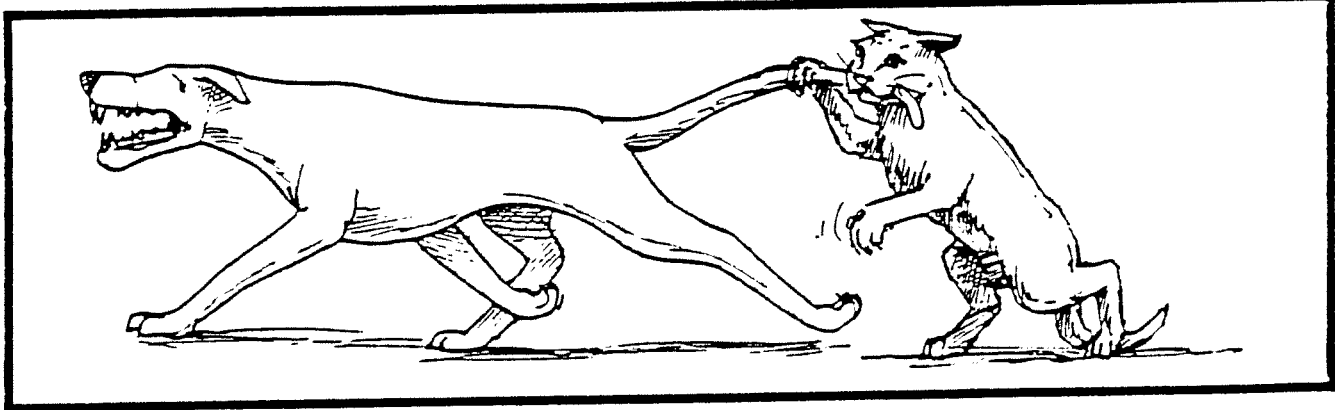

4

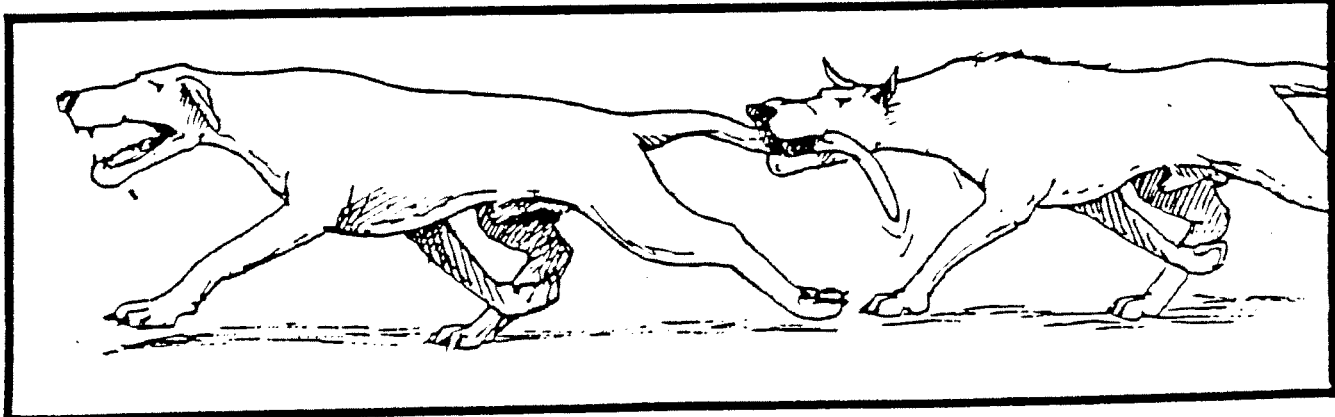

1

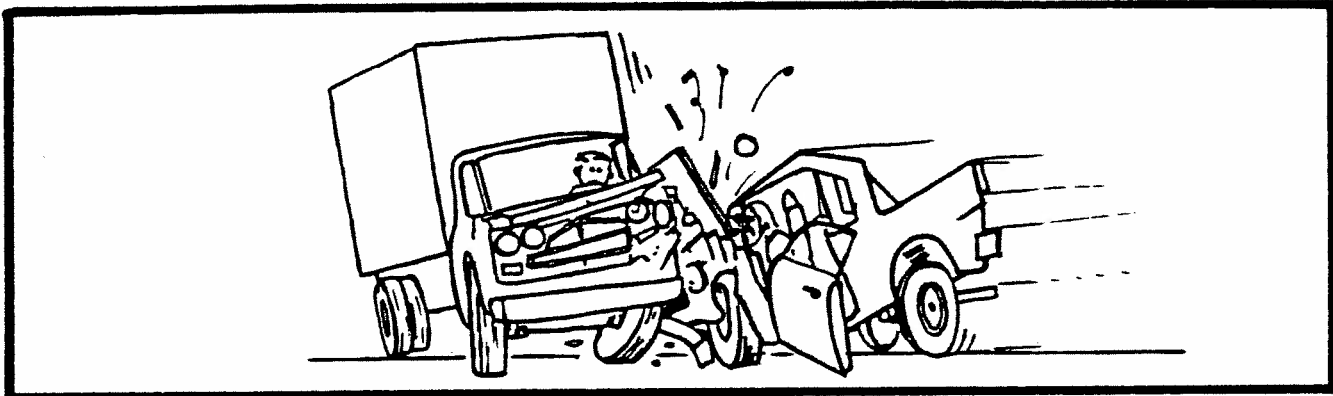

2

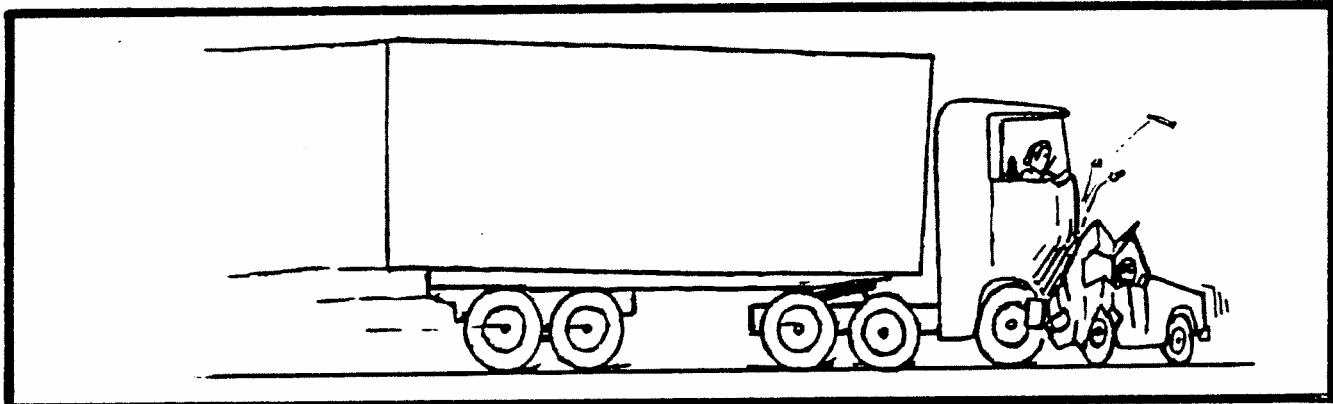

3

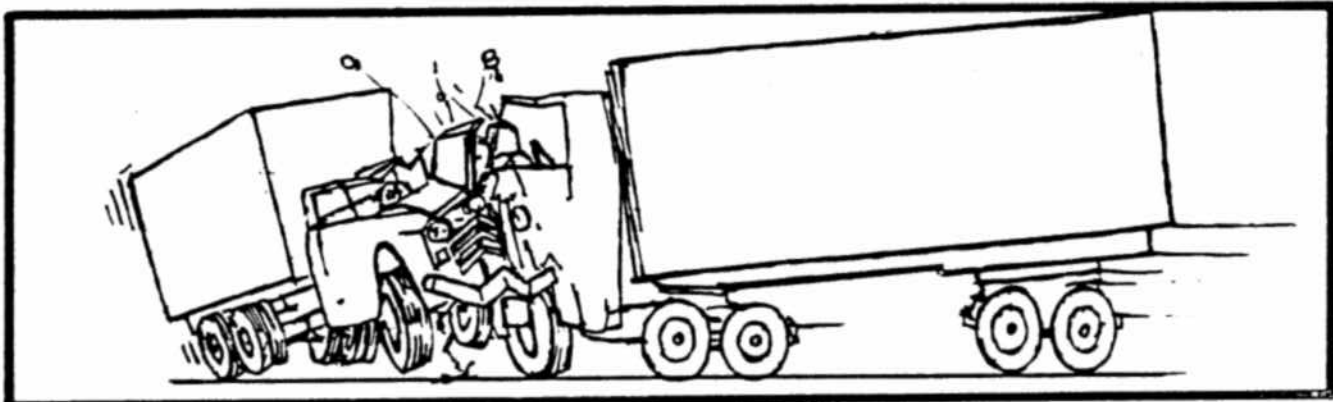

4

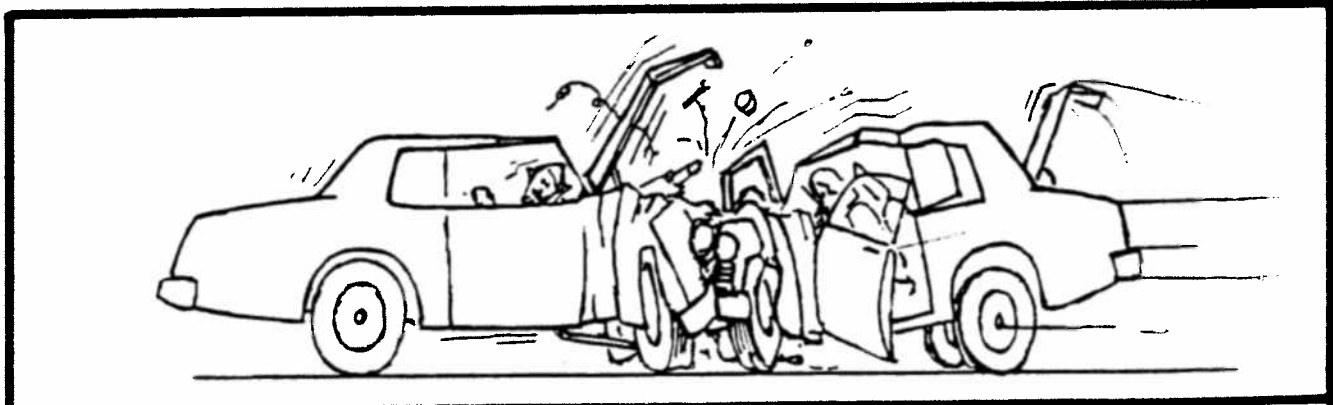

6

1

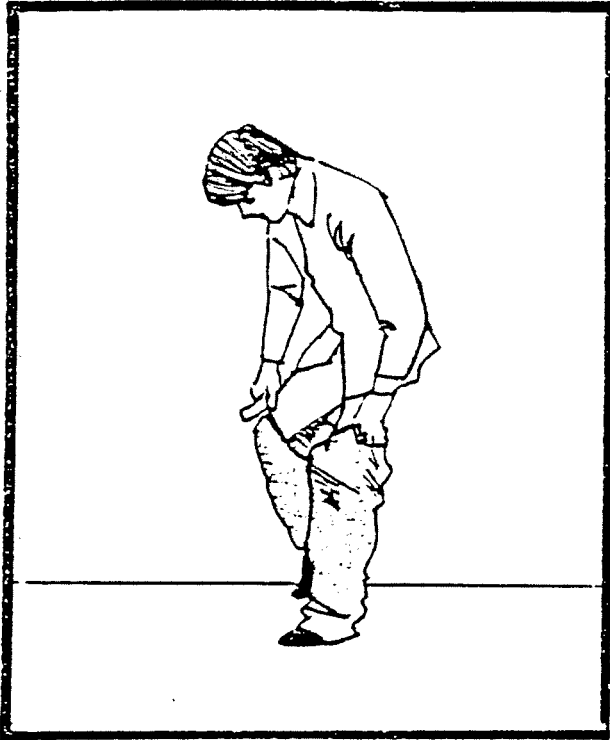

2

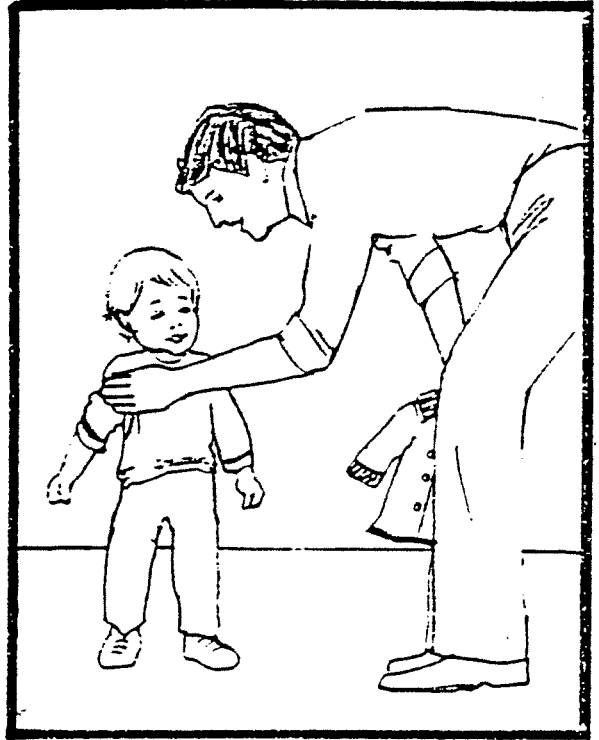

3

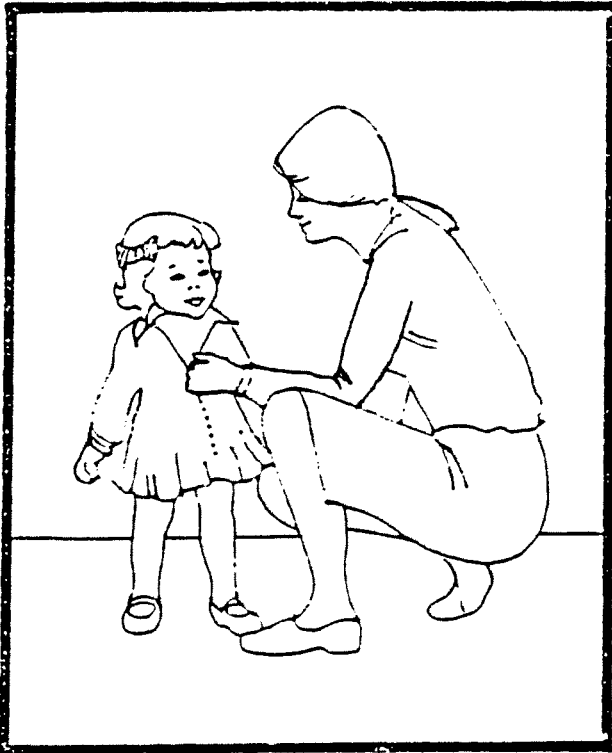

4



7

1

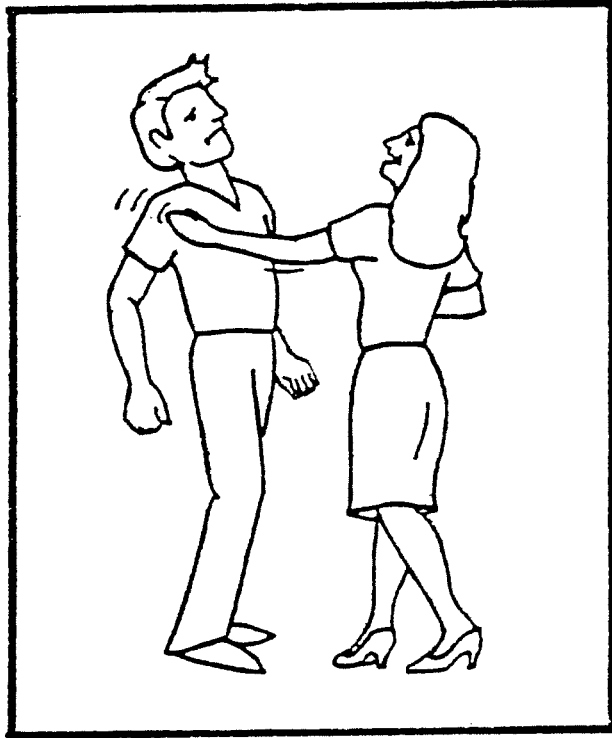

2

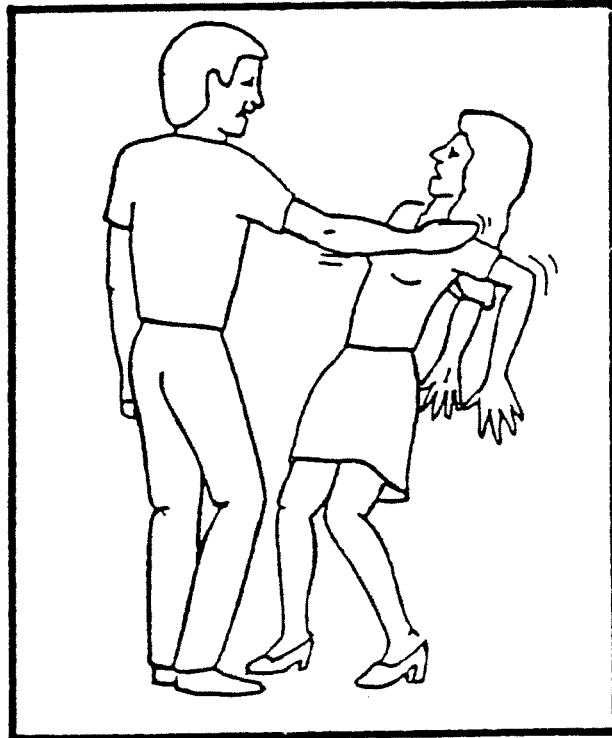

8

1

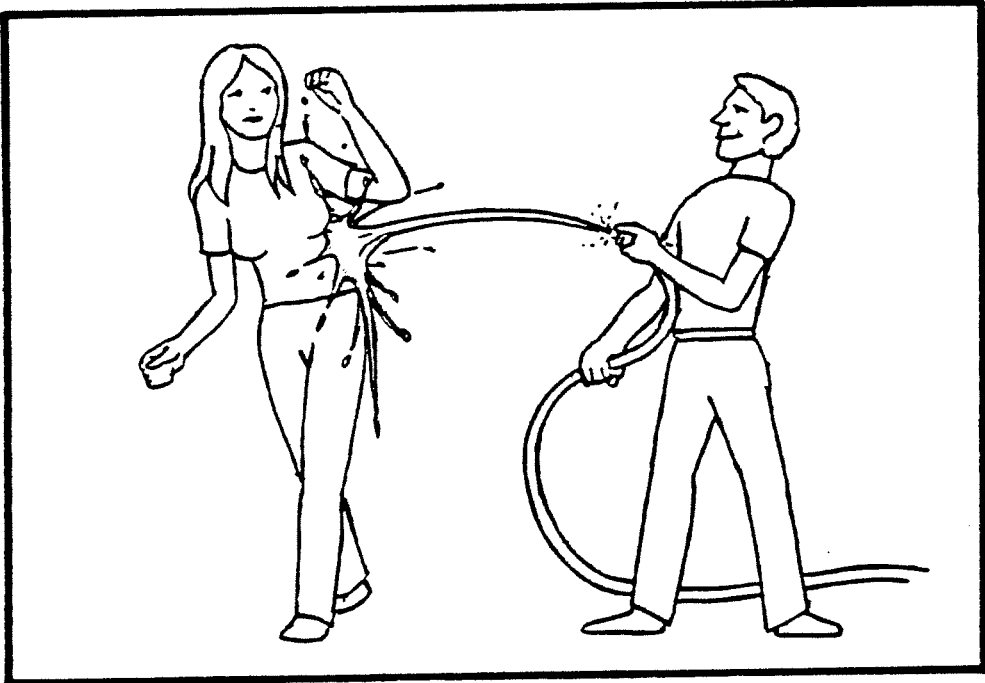

2

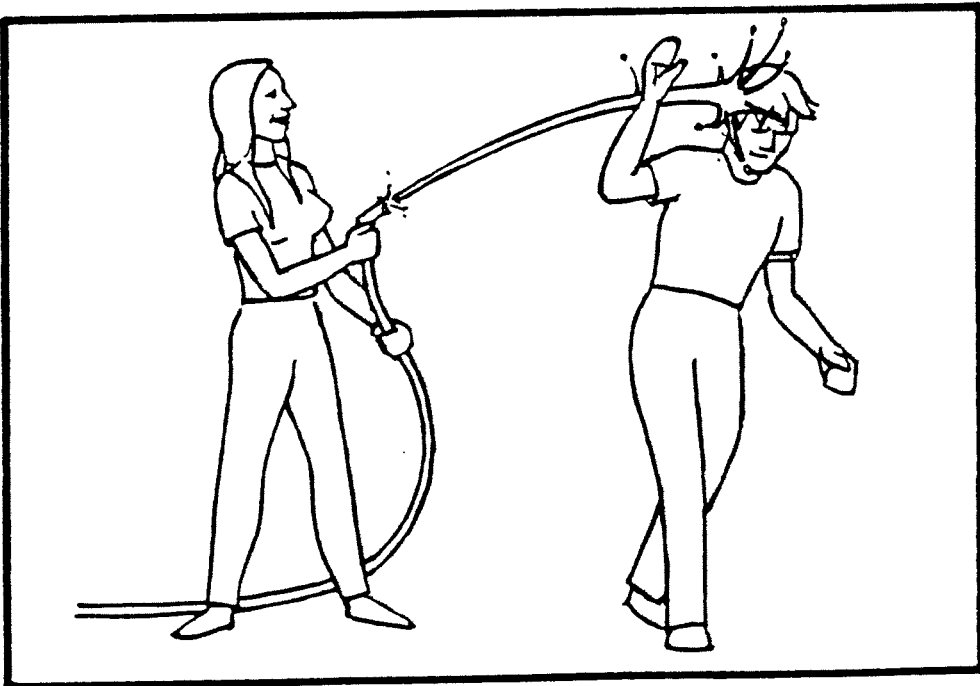

1

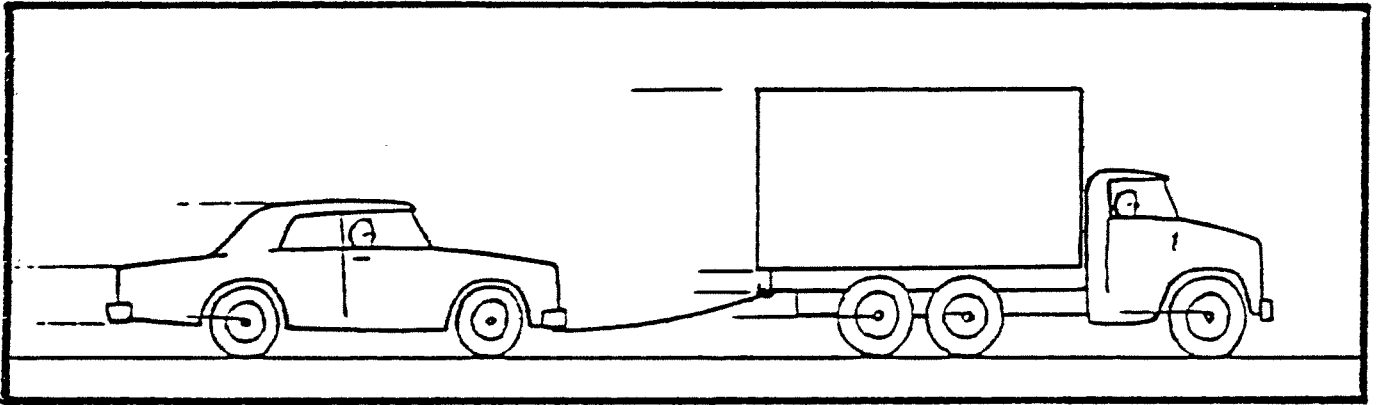

2

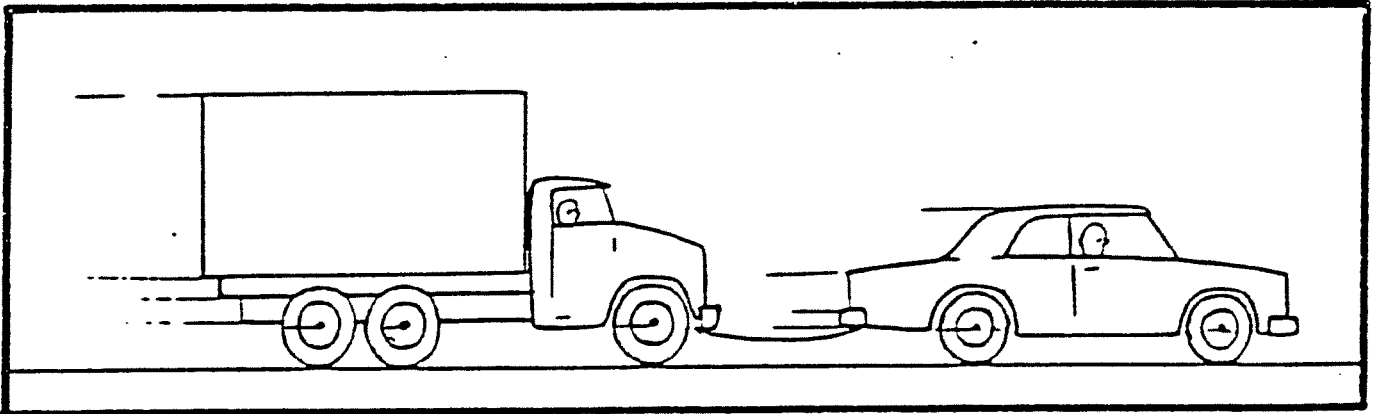

10

1

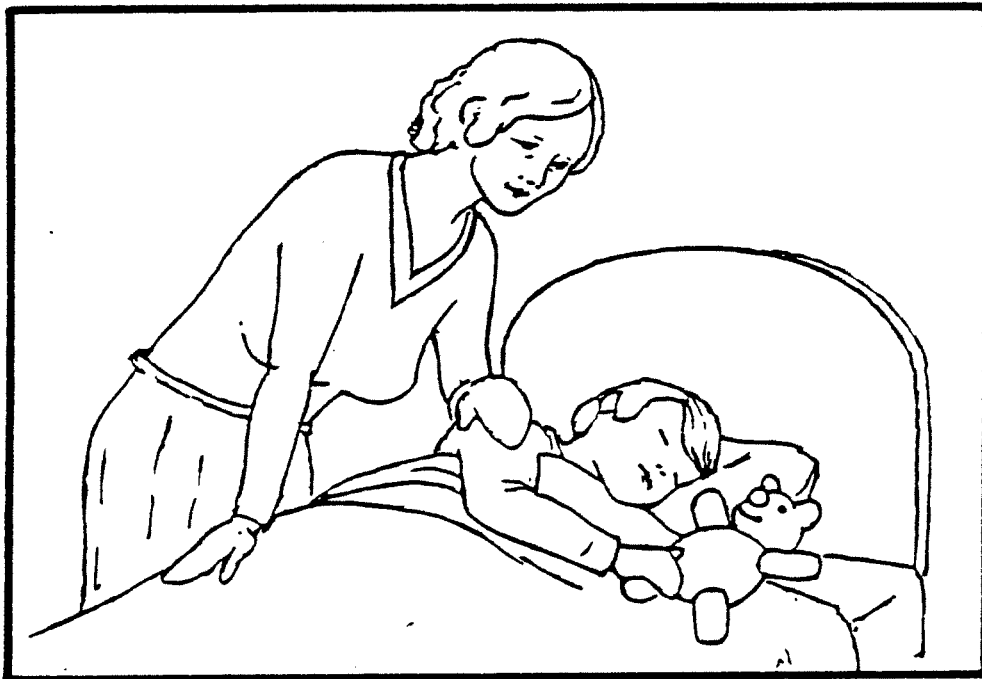

2

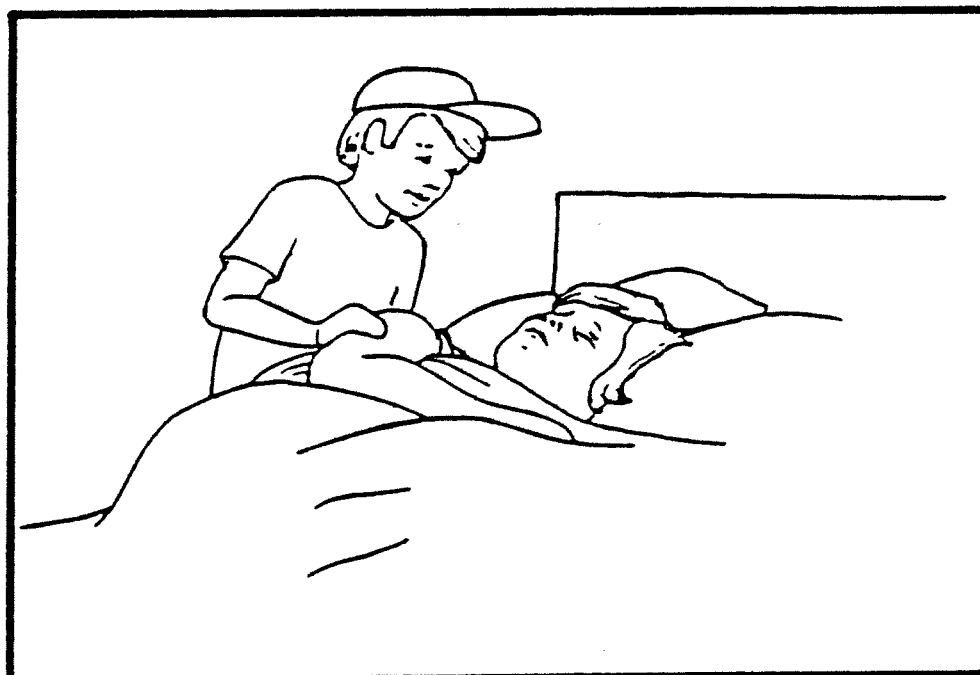

1

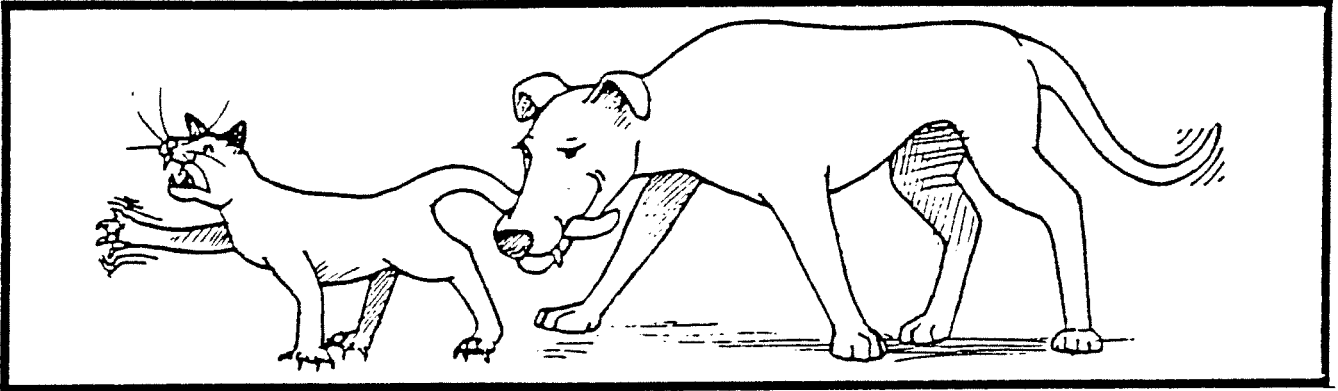

2

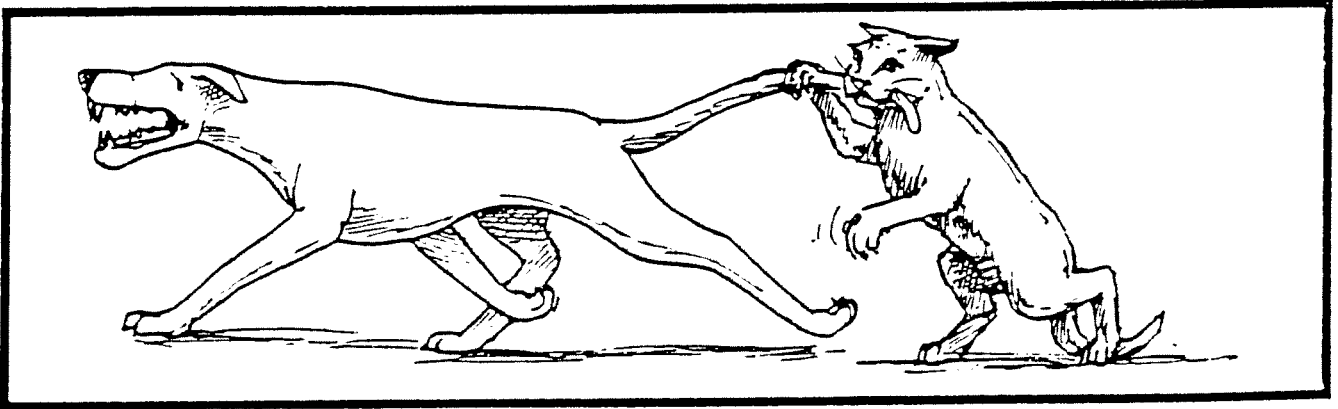

12

1



2



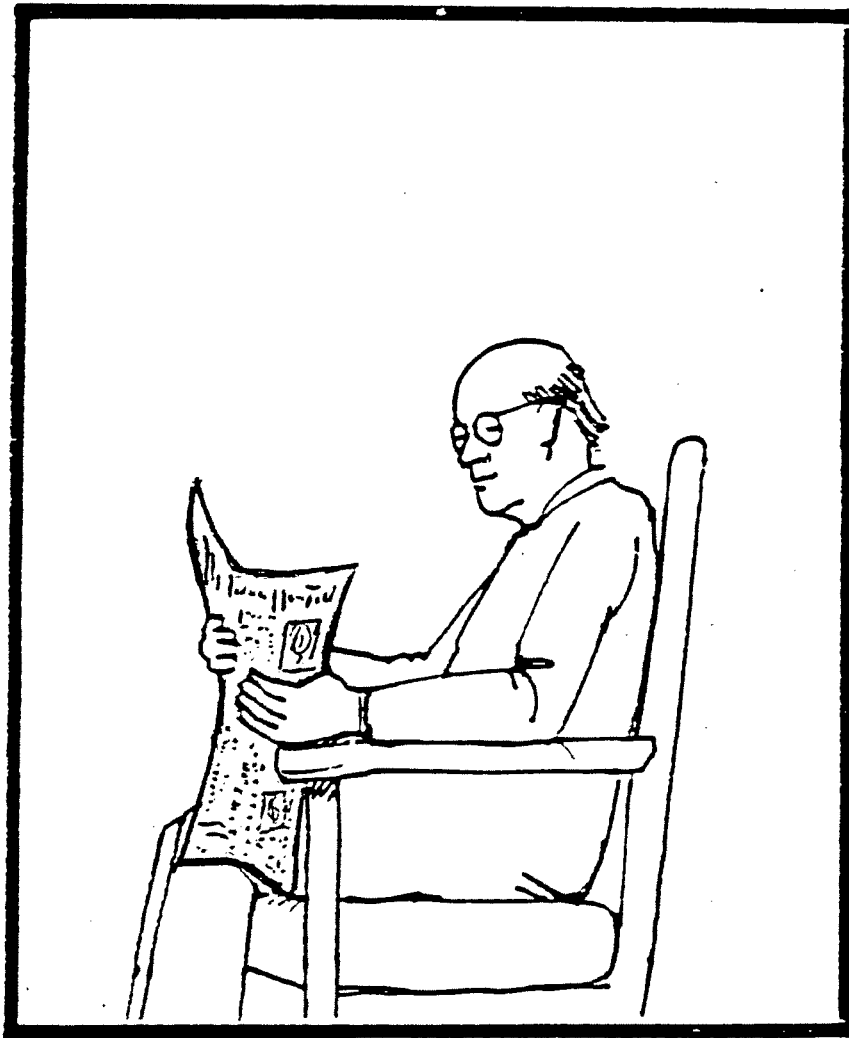

1

2



2

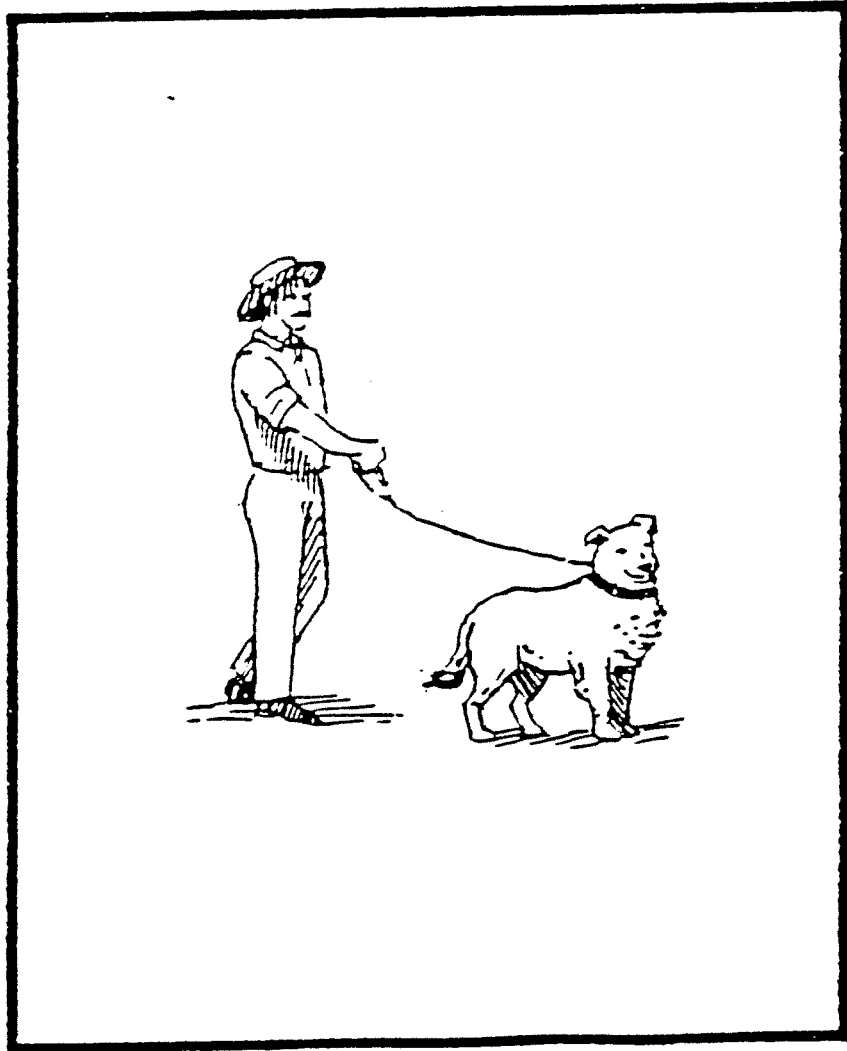

1

2

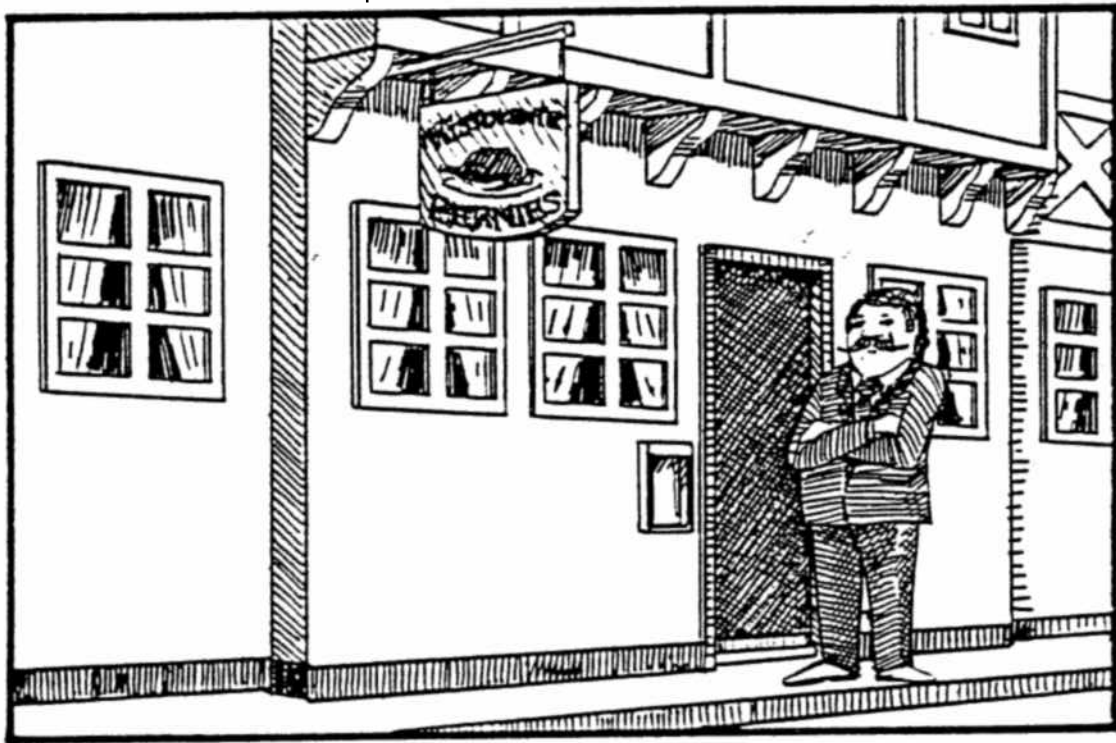

2

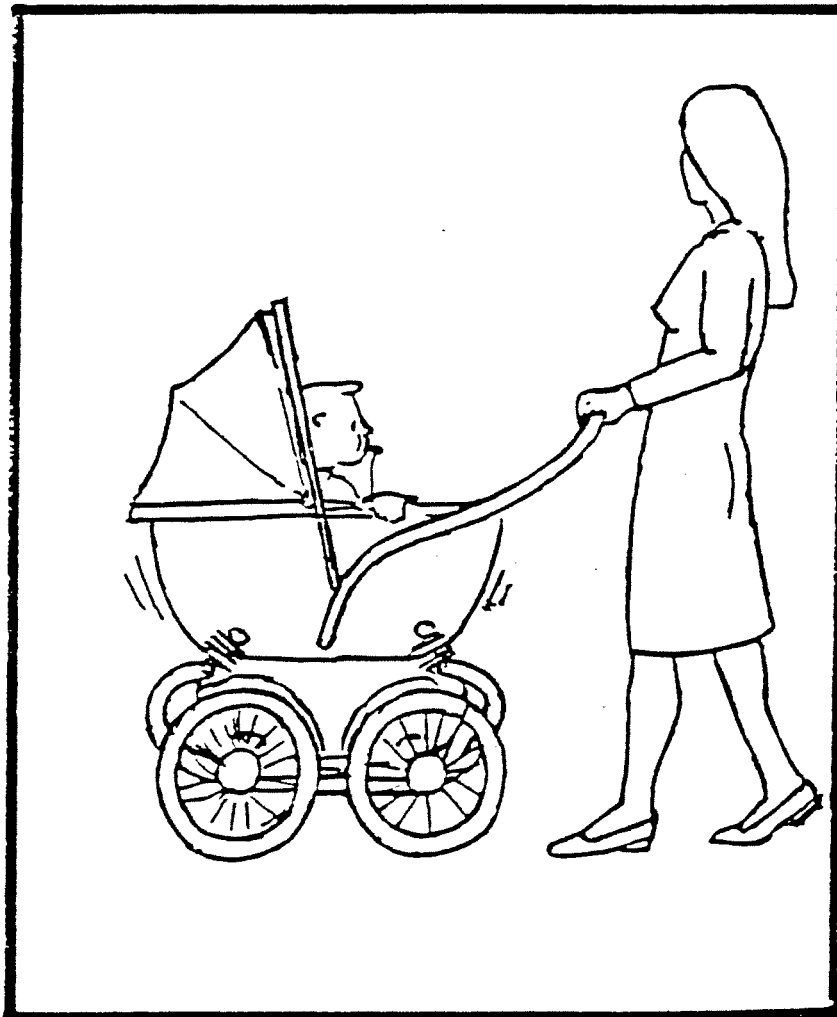

2



1



2

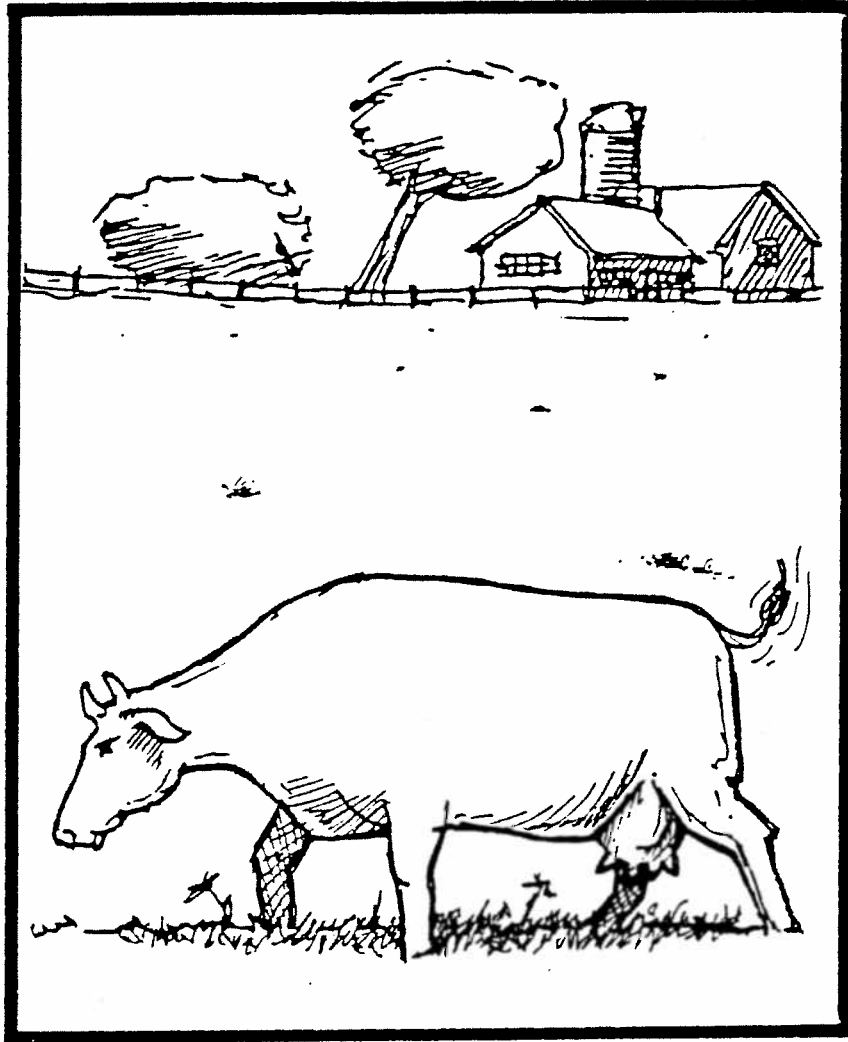

1

2

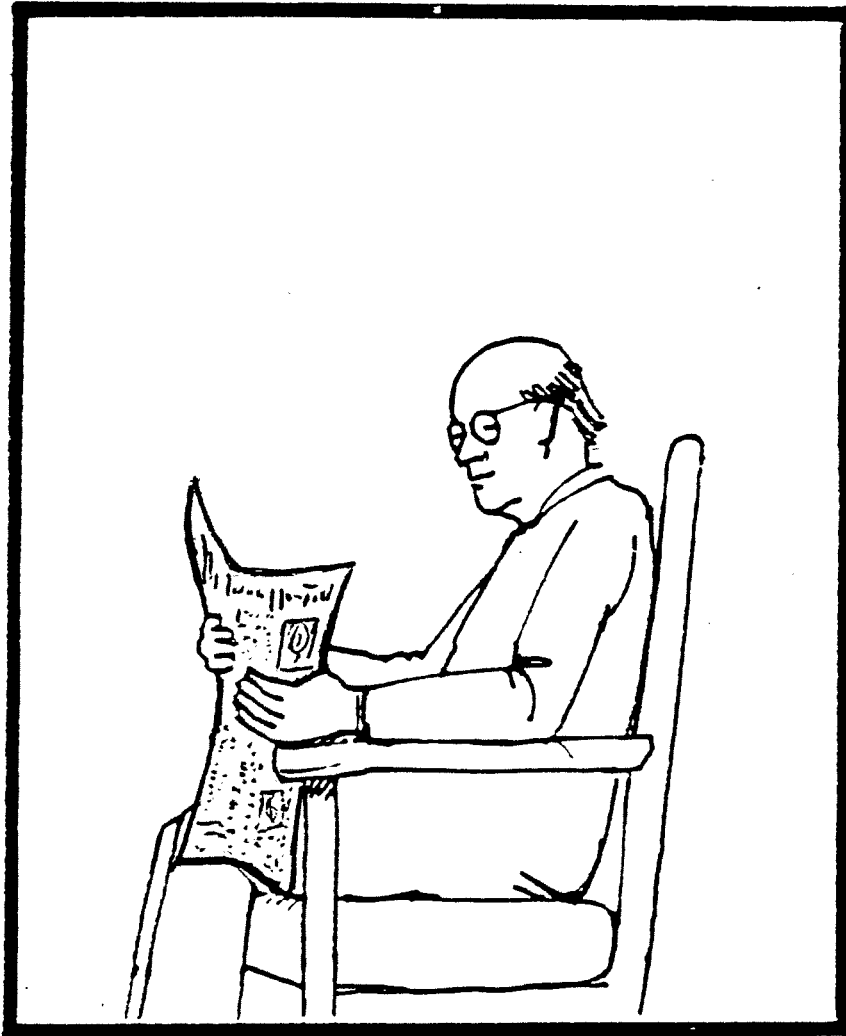



2

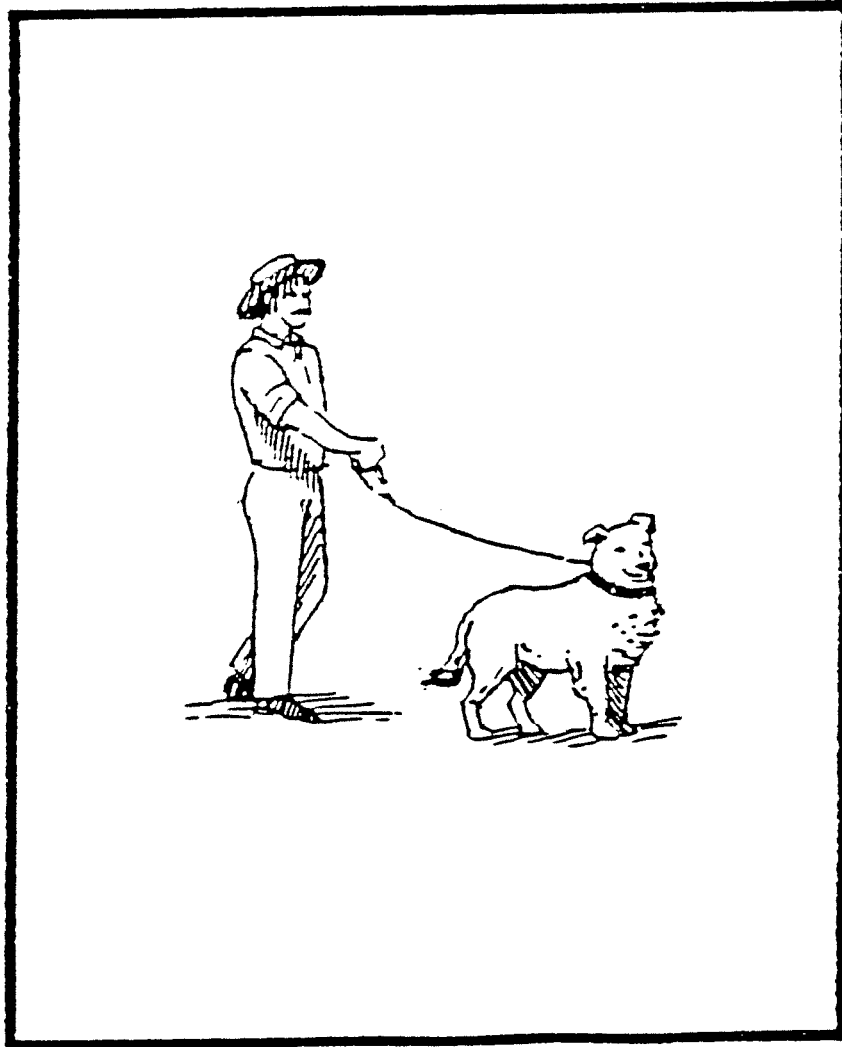

1

2

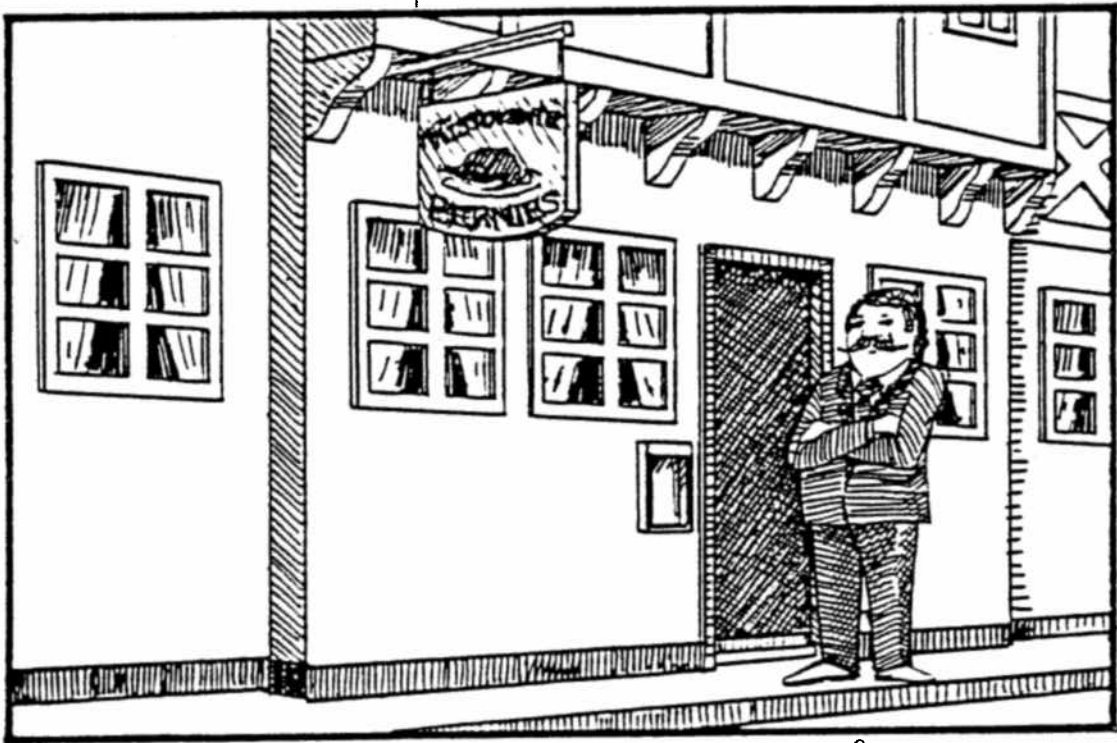

2

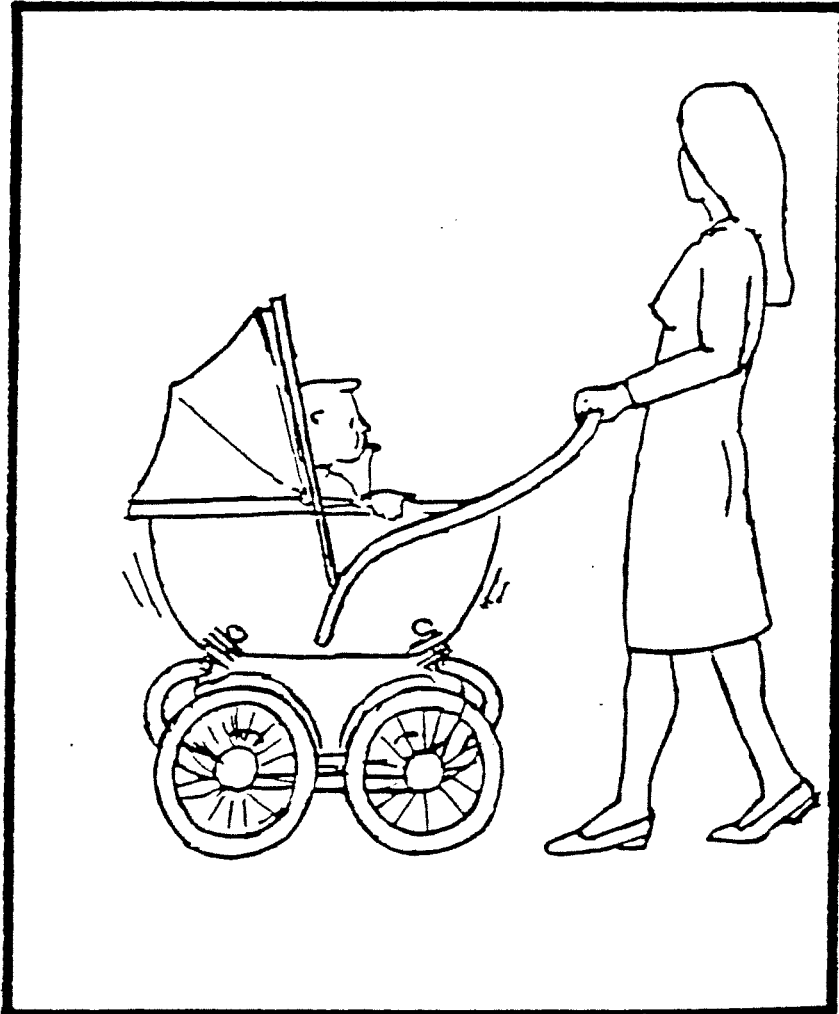

1

2

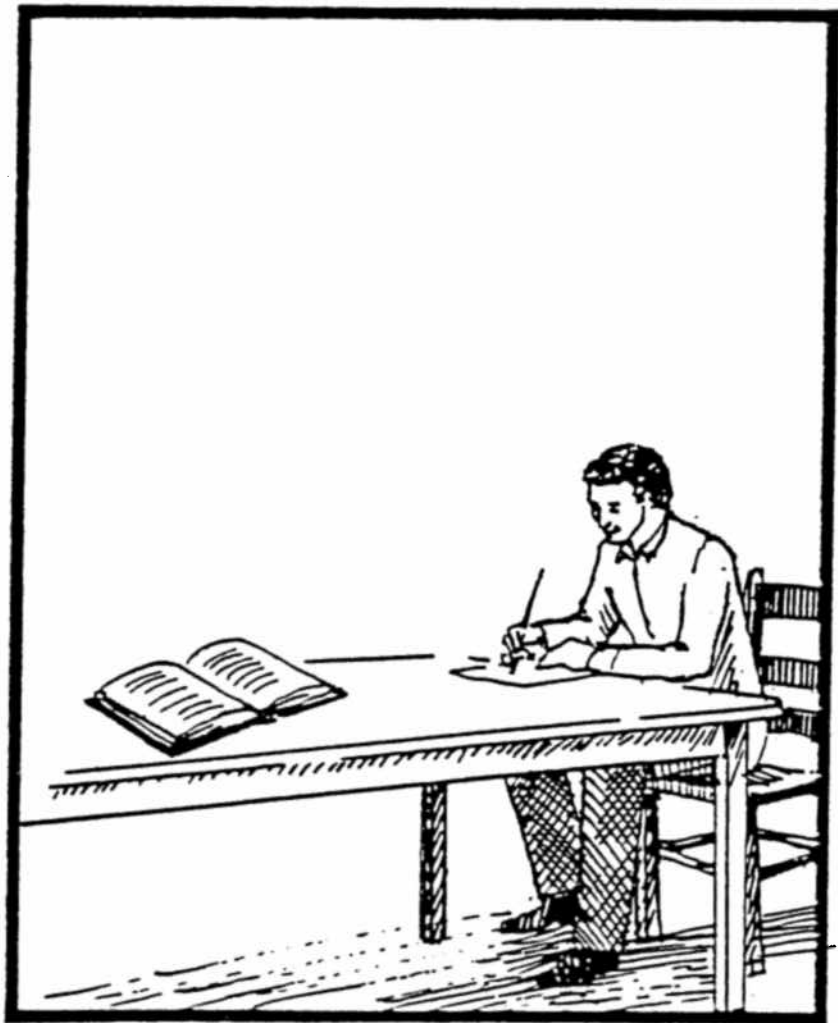

1



2

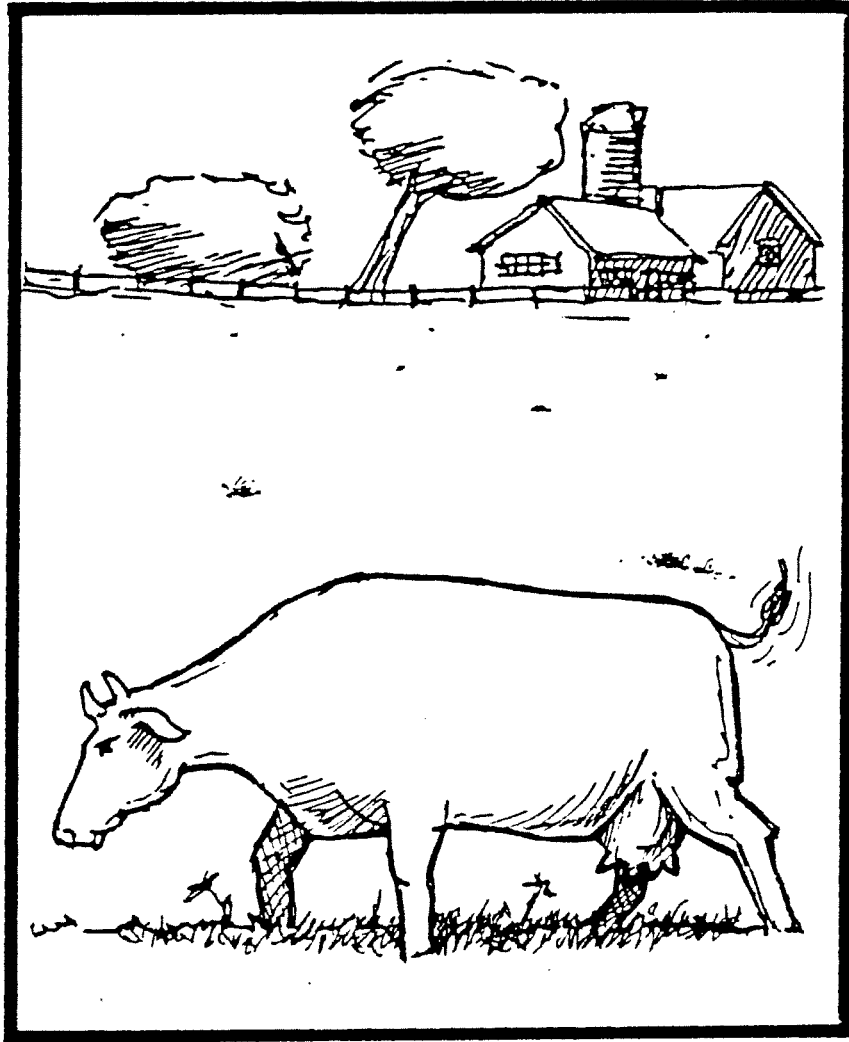

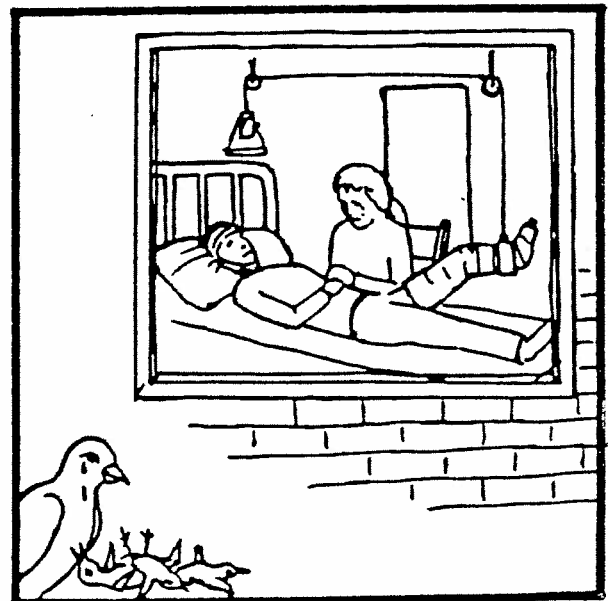
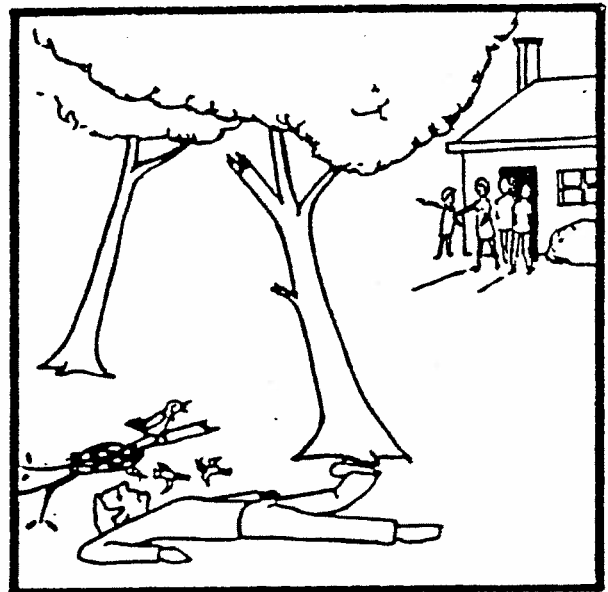
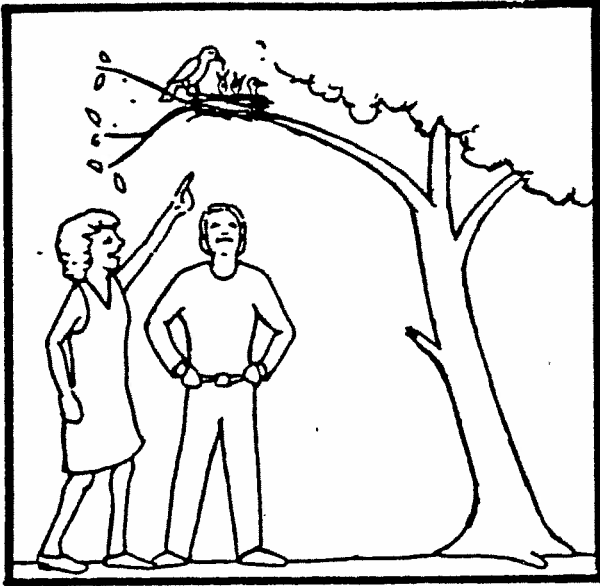

mier

roer

mus

luis

tand

hout

pak

kast

poot

taart

De jongen houdt het meisje vast

Zij wast haar

De kat wordt door de hond gebeten

Het is de vrachtwagen die de auto aanrijdt

De jongen duwt het meisje niet

De vrachtwagen wordt niet door de auto gesleept

Dat is de hond die de kat bijt

Hij houdt haar vast

Het meisje wordt door de jongen geduwd

De jongen wordt door het meisje nat gespoten

Een vrouw ging met haar dochterje wandelen. Ze zijn bloemen gaan plukken. Terug in het dorp zijn ze naar de markt gegaan en daar hebben ze de bloemen tegen kerzen verwisseld.

bad

kus

land

buis

moer

BEGRIPSVERMOGEN VOOR GESCHREVEN WOORDEN

mier

1

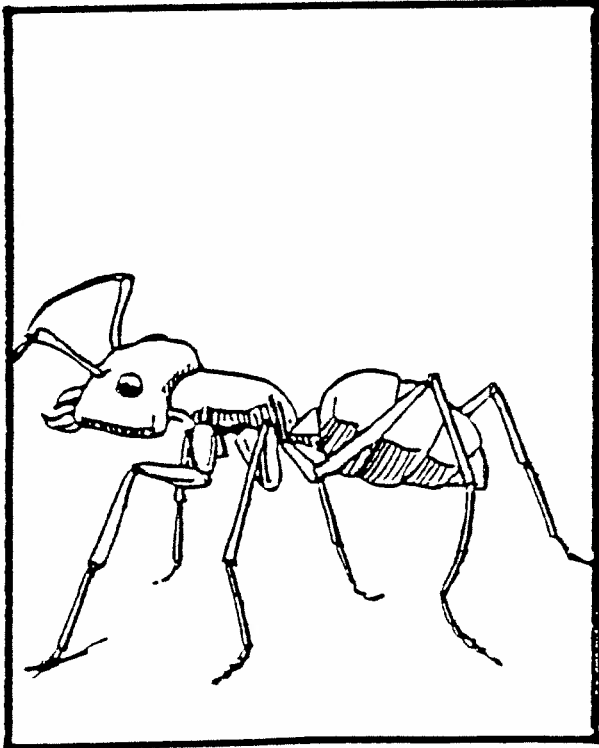

2

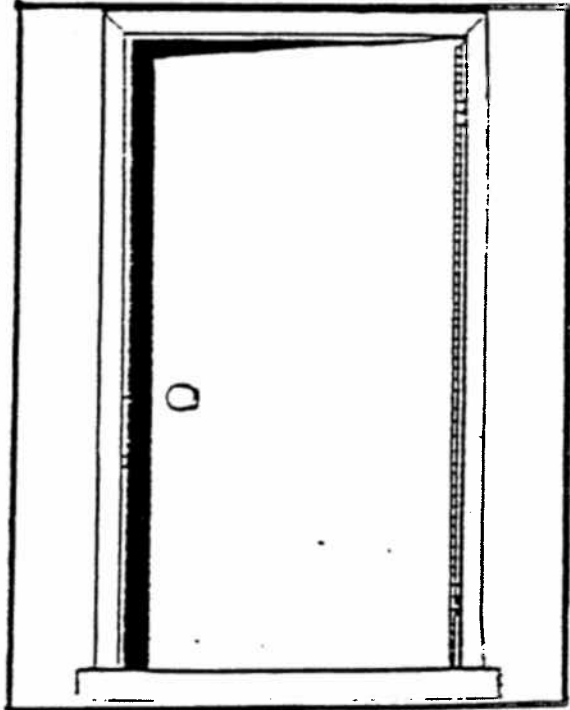

3

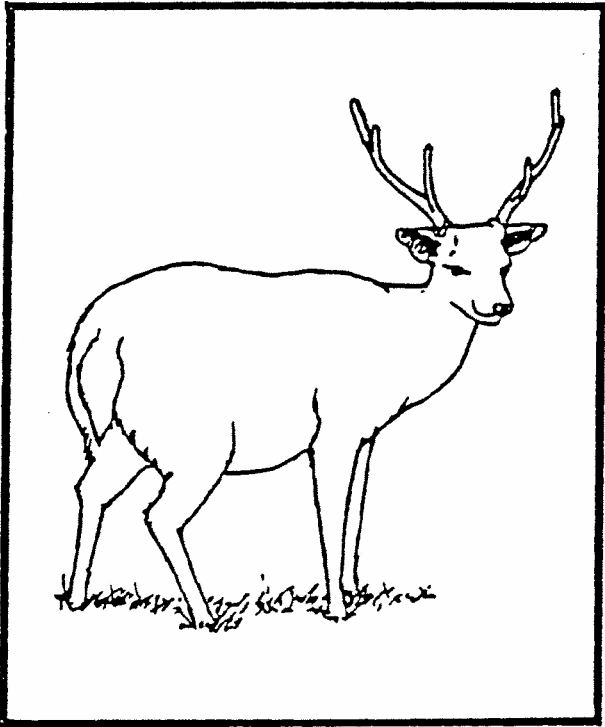

4

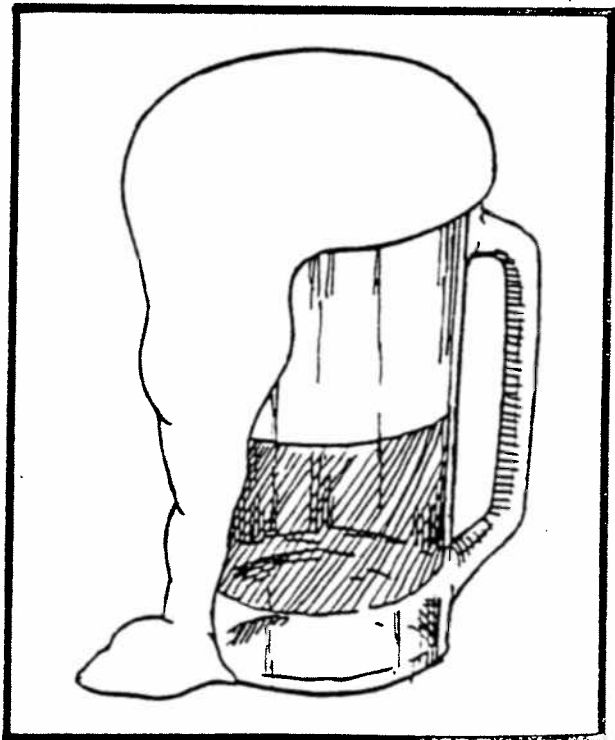

roer

1

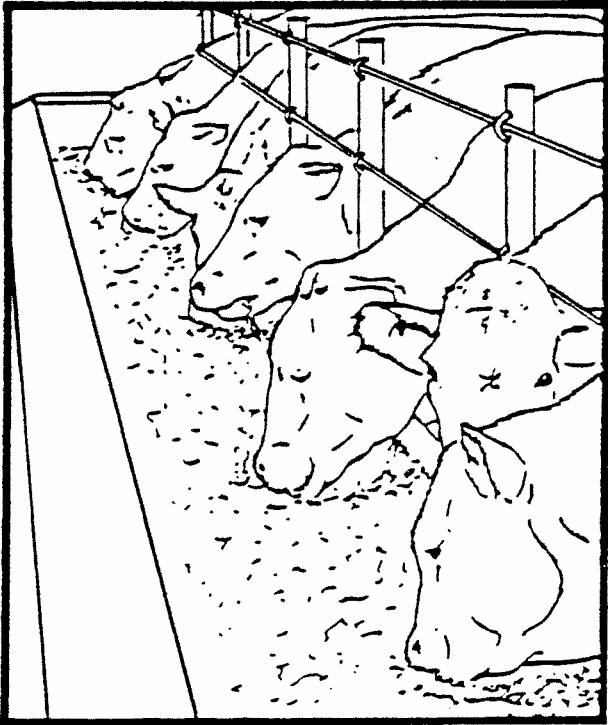

2

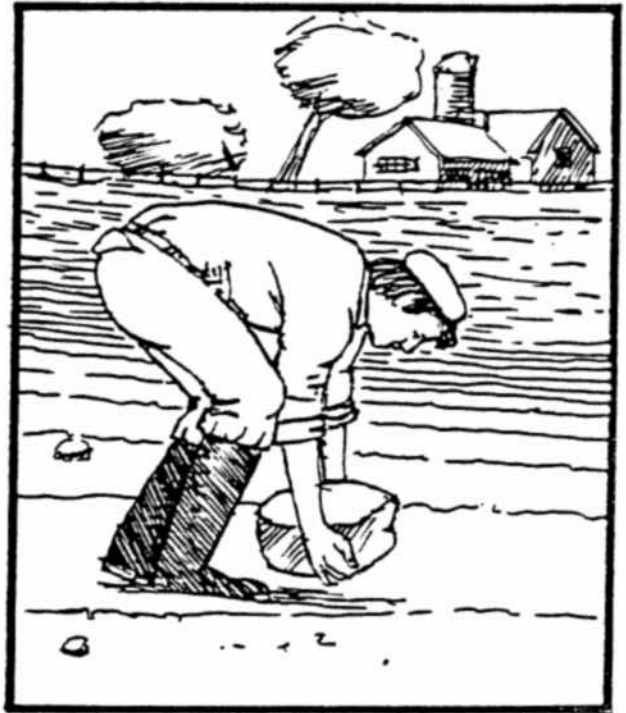

3

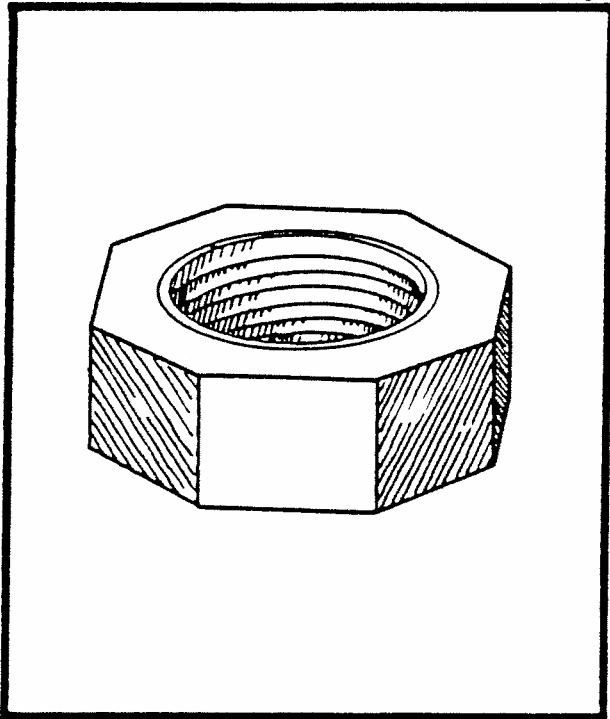

4

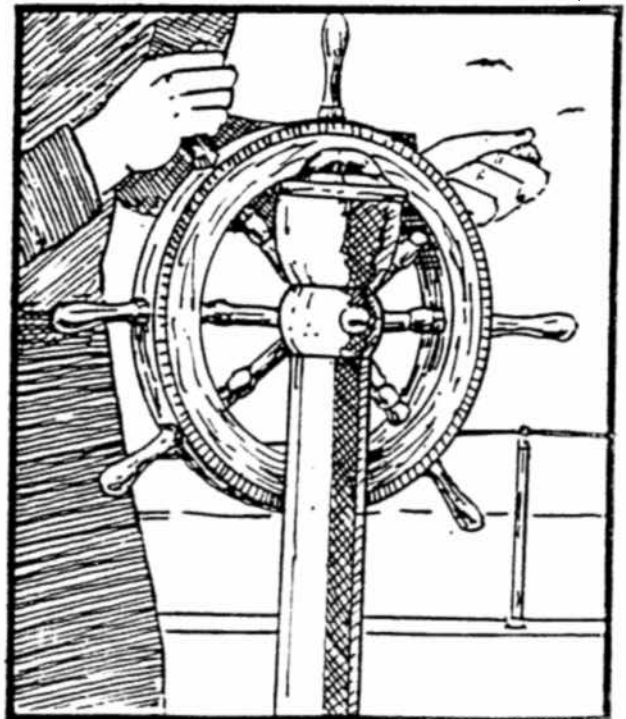

mus

1

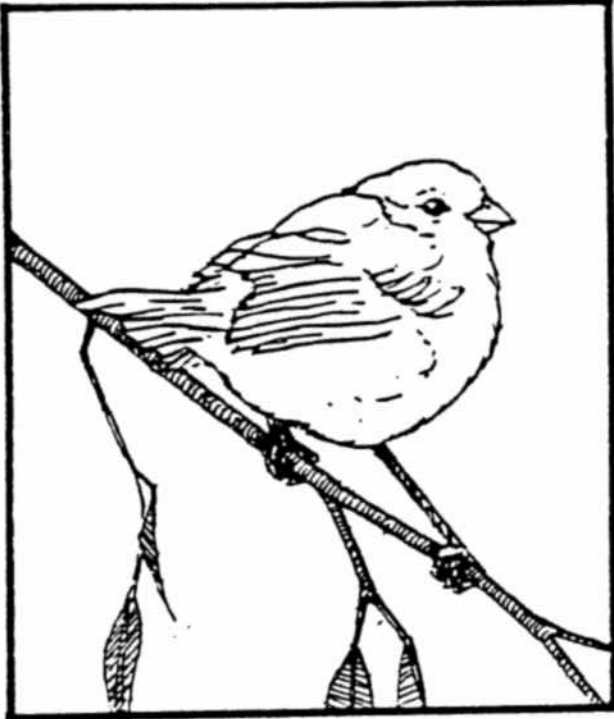

2

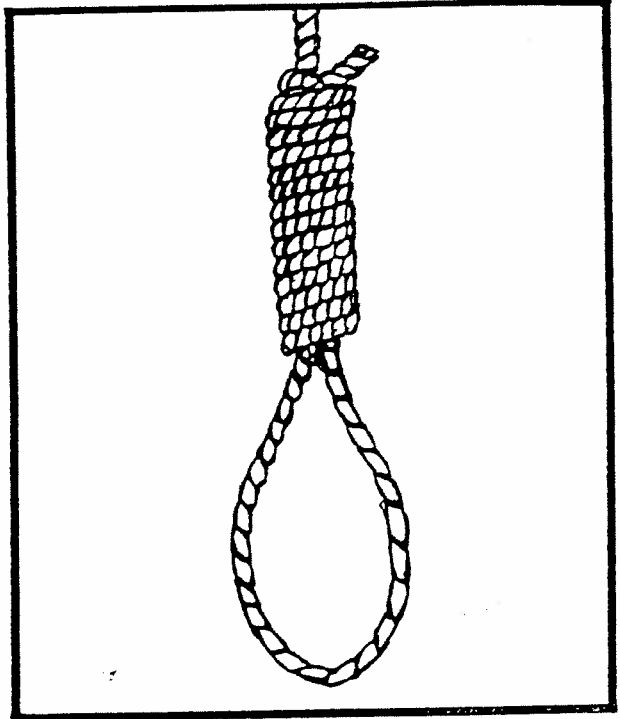

3



4

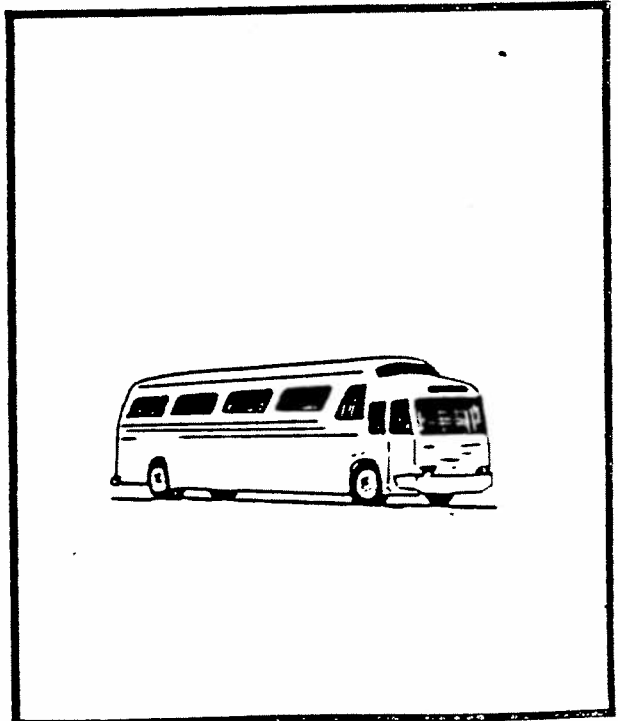

luis

1

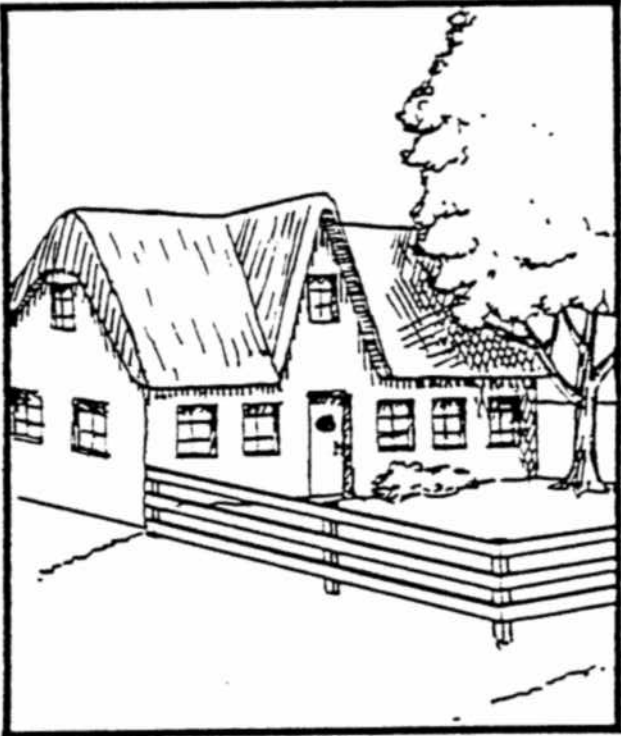

2

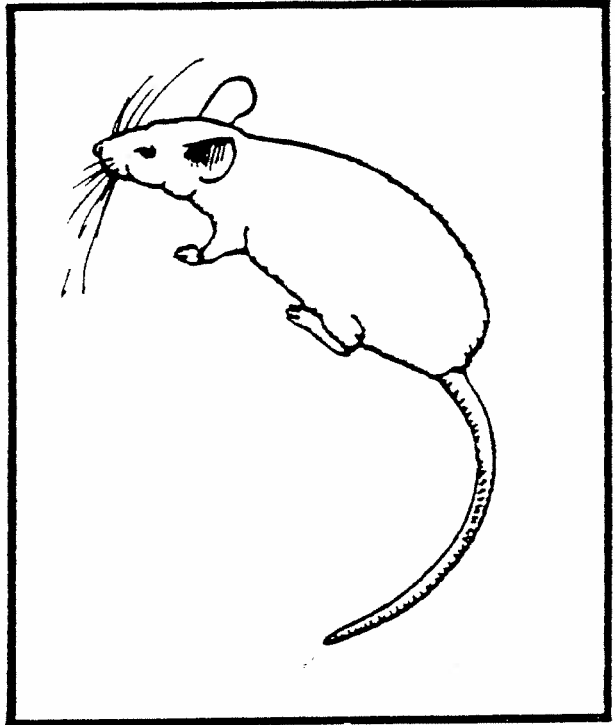

3

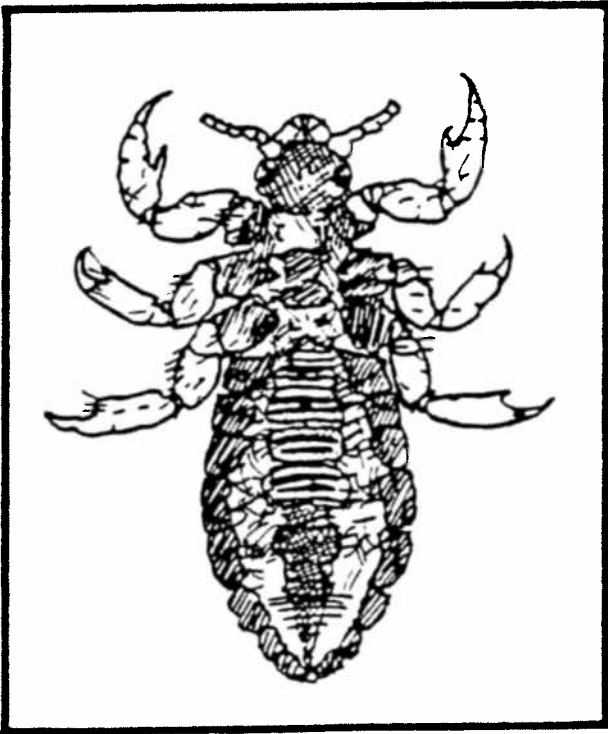

4

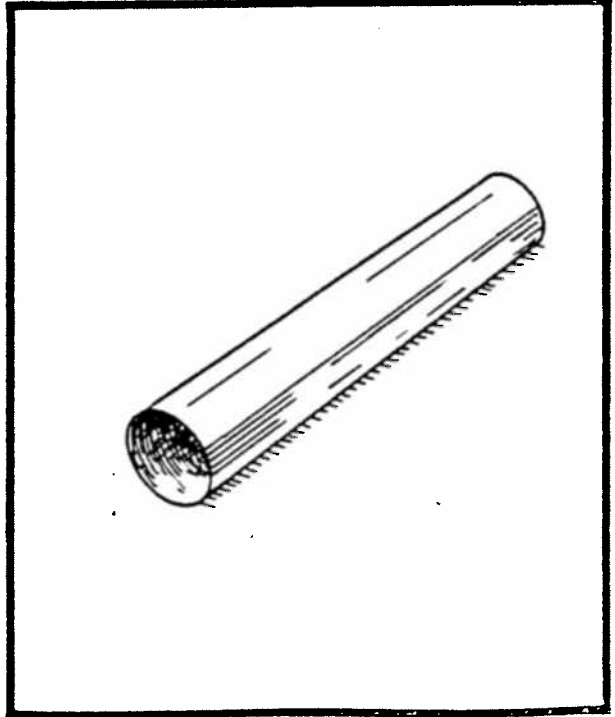

tand

1

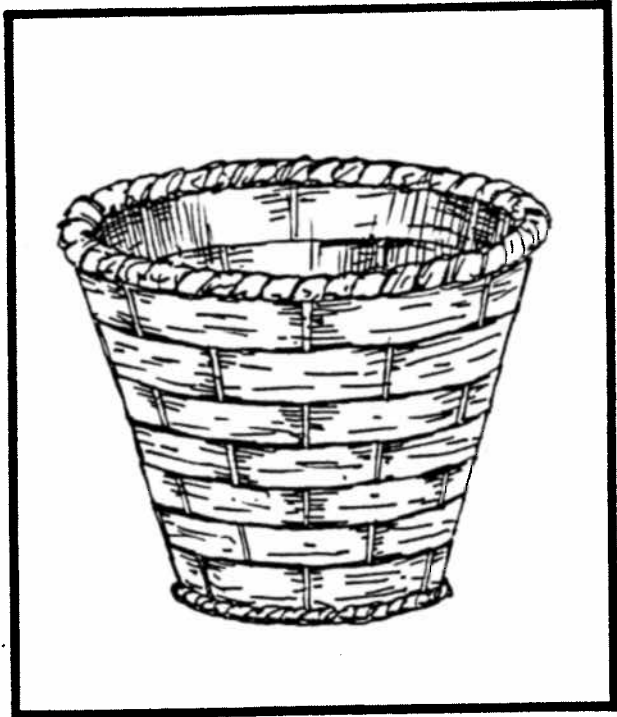

2

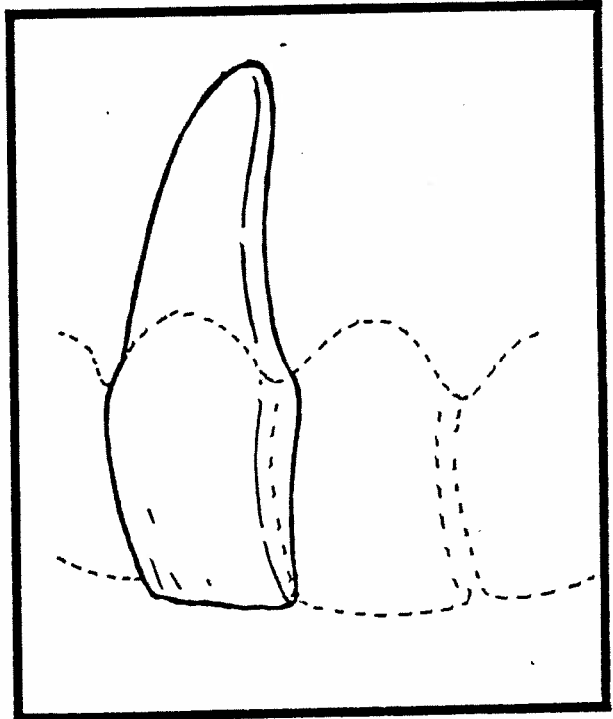

3

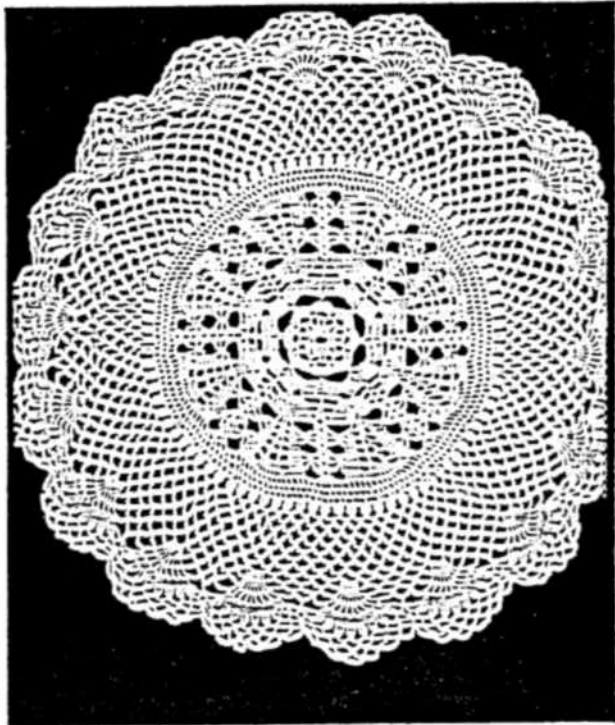

4



hout

1

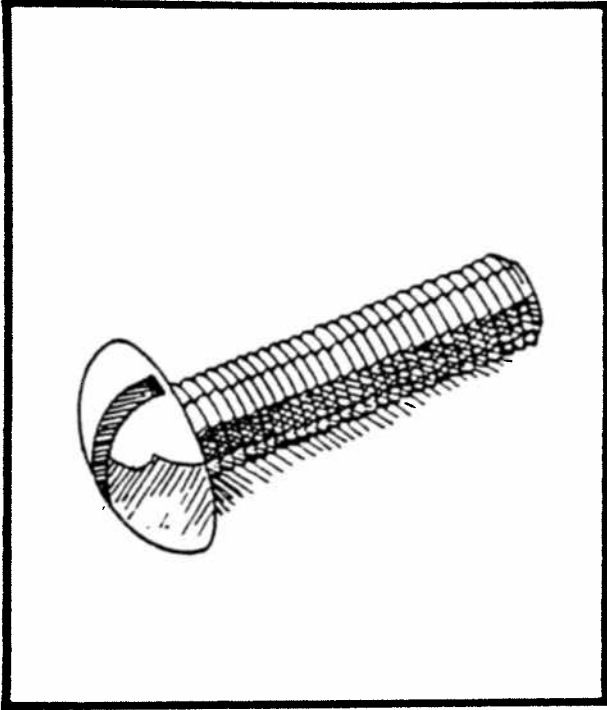

2

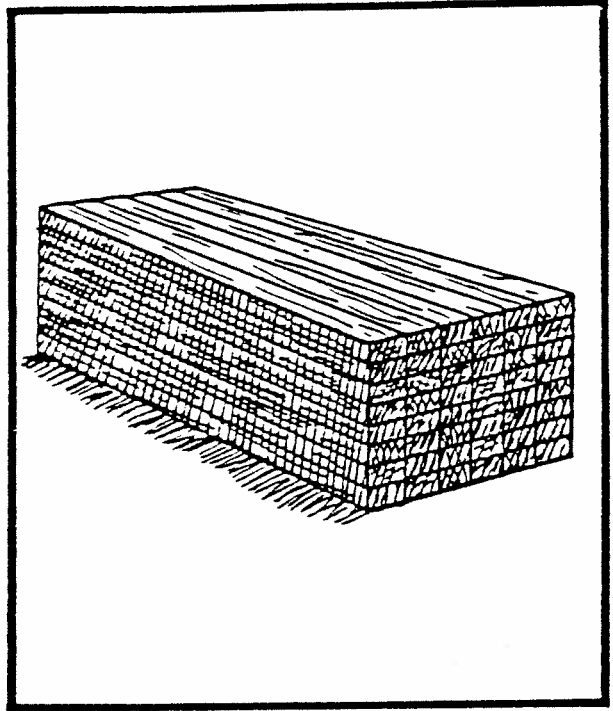

3

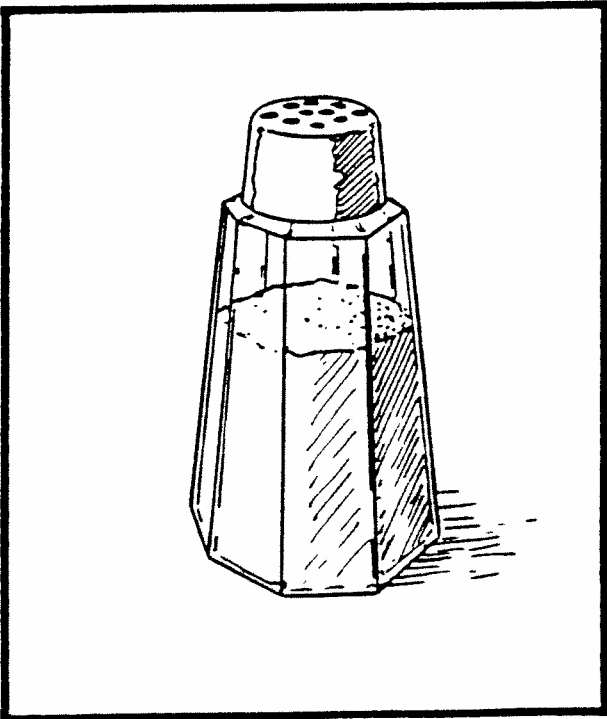

4

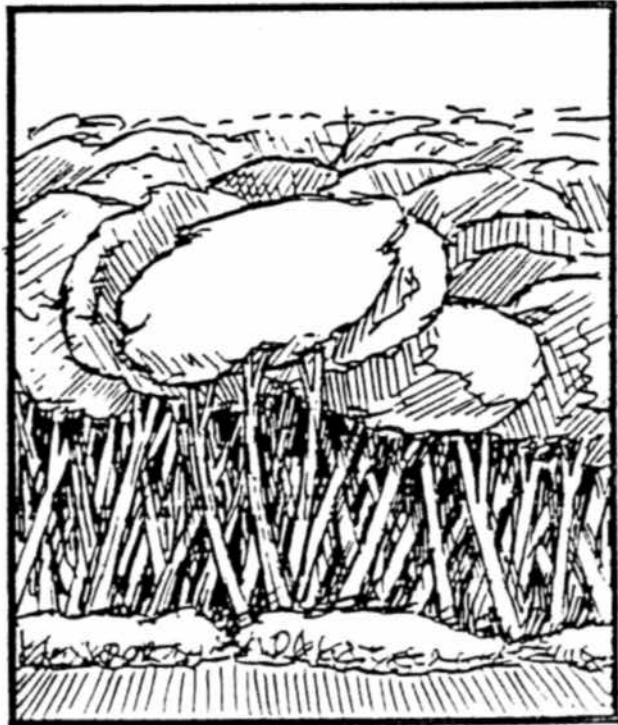

pak

1

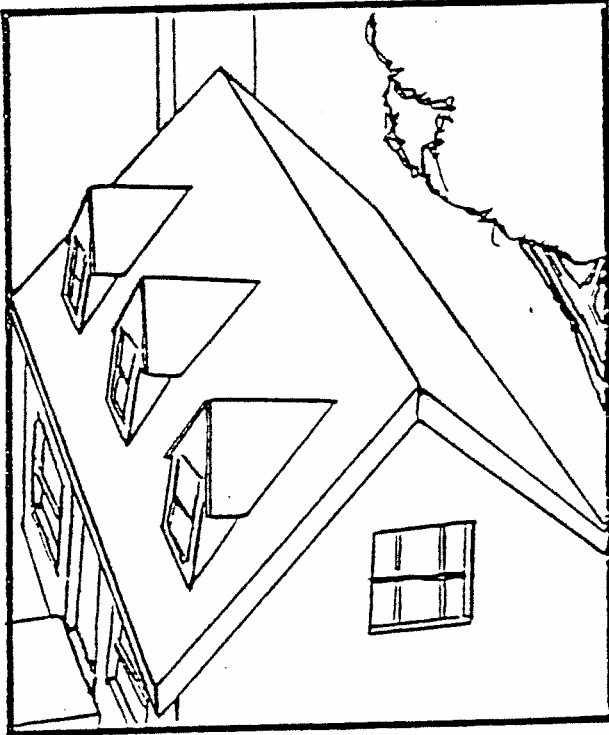

2

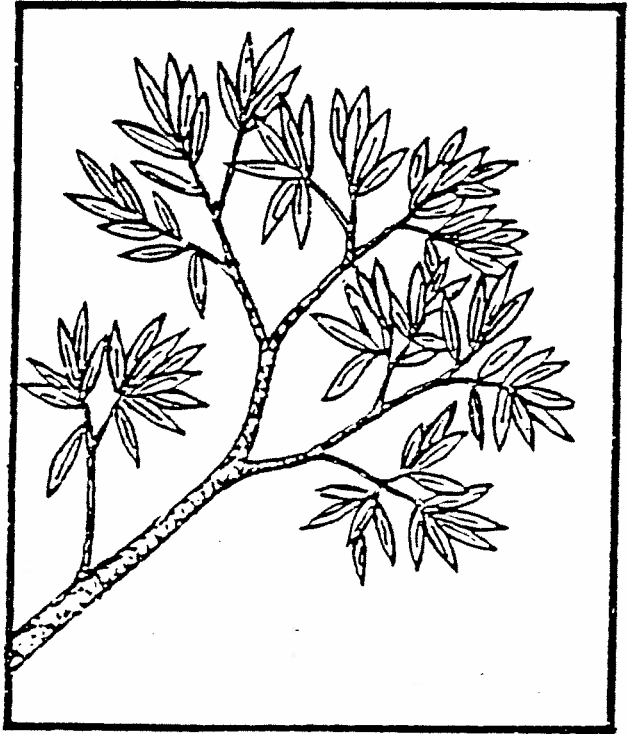

3

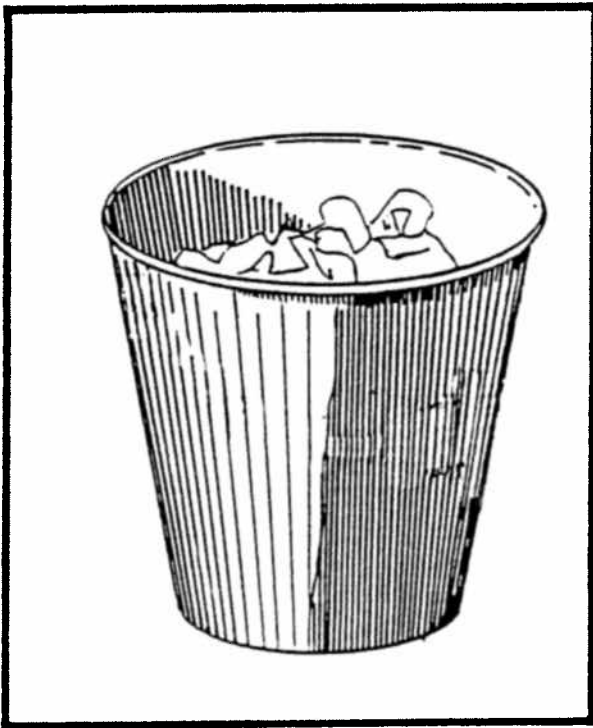

4

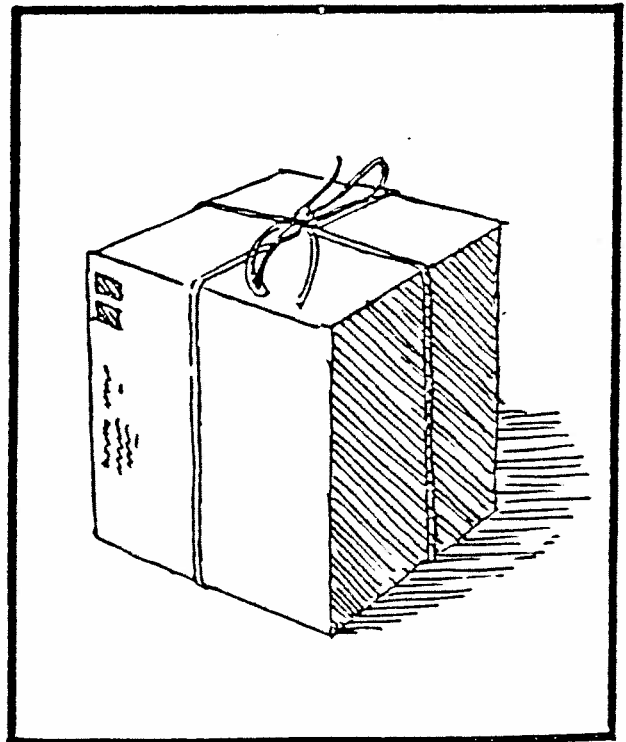

kast

1

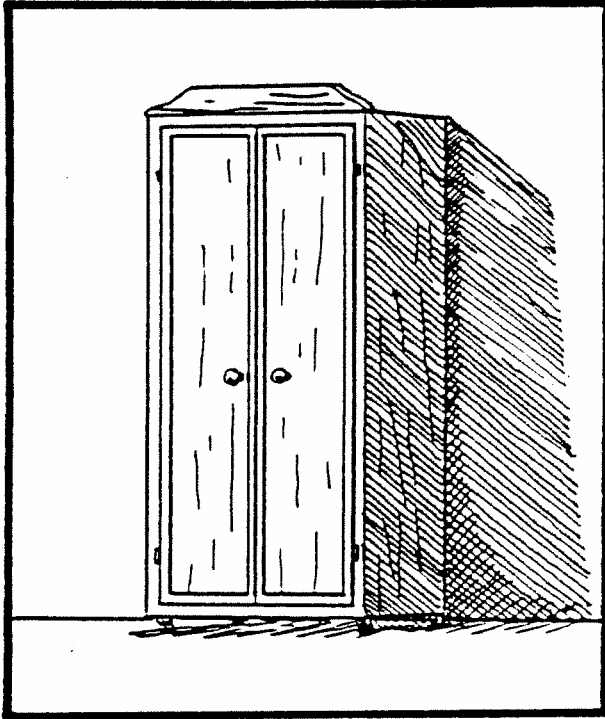

2

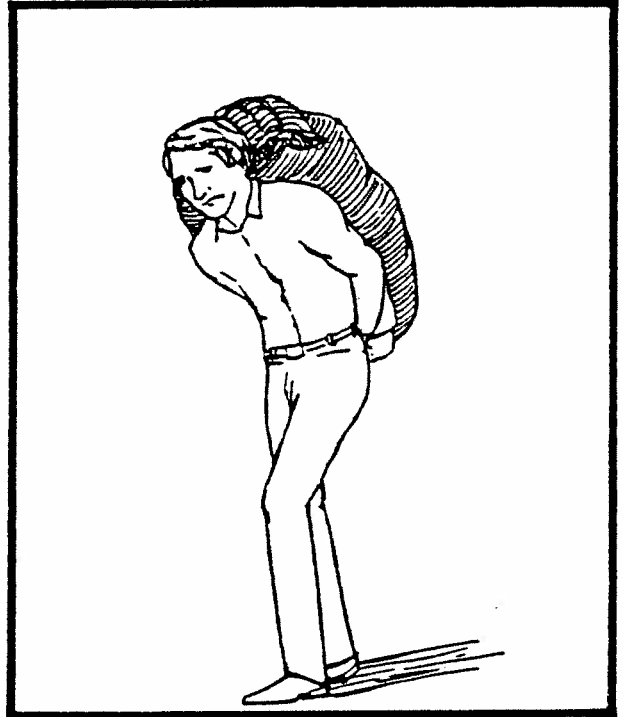

3

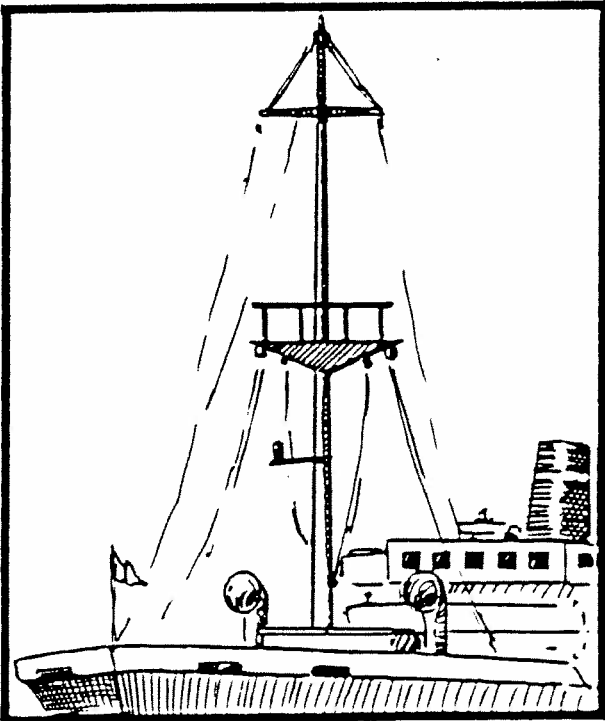

4



poot

1

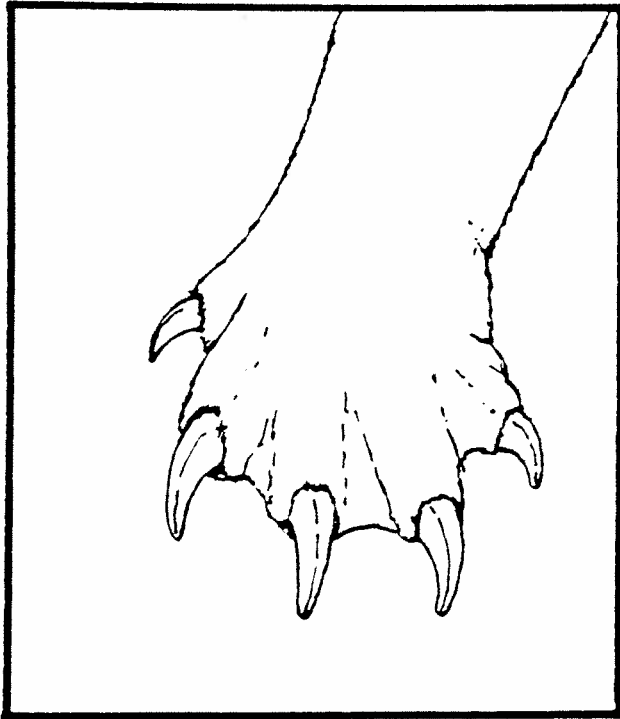

2

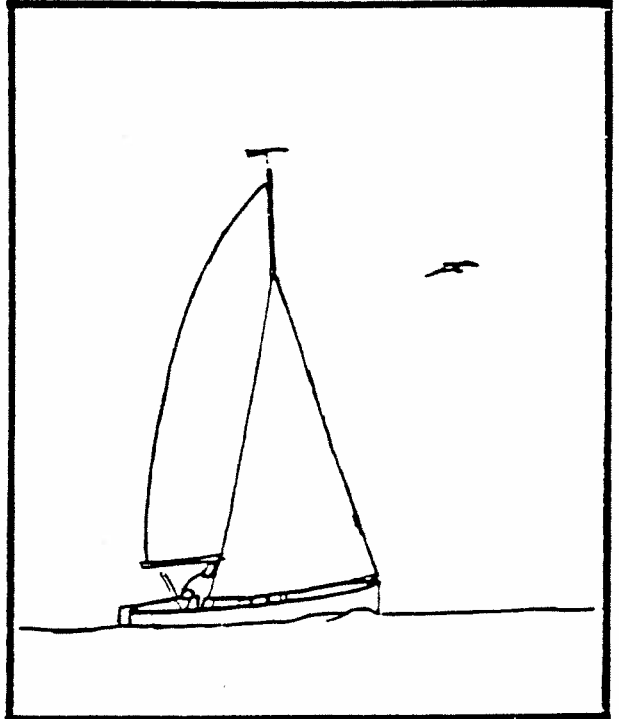

3

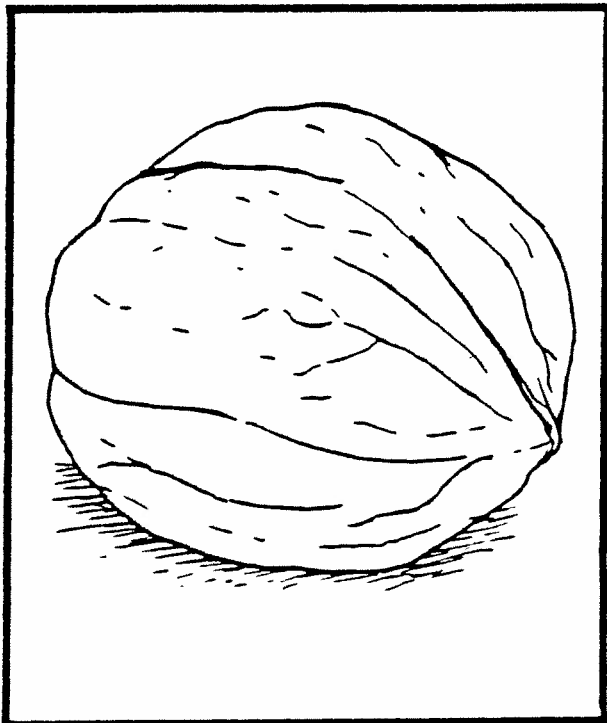

4

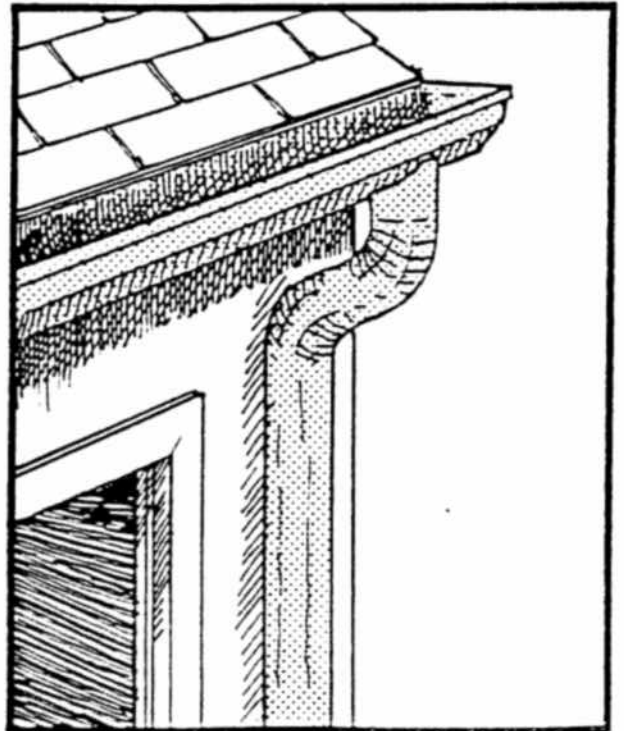

taart

1

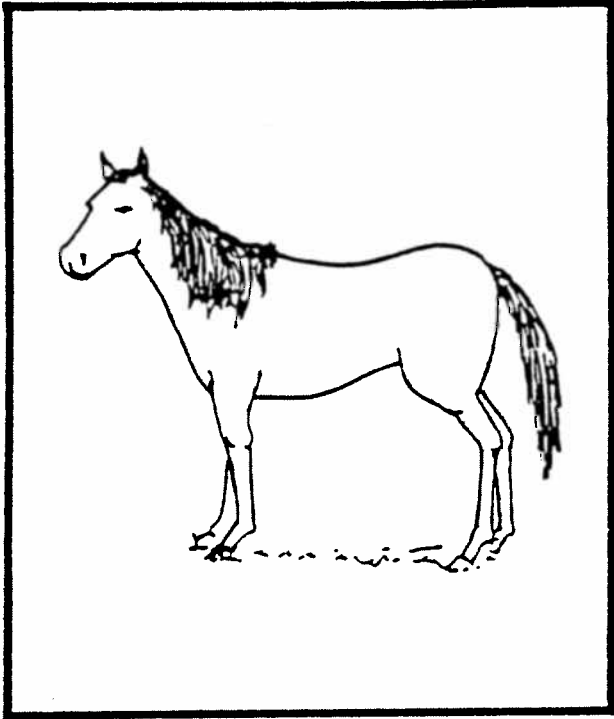

2

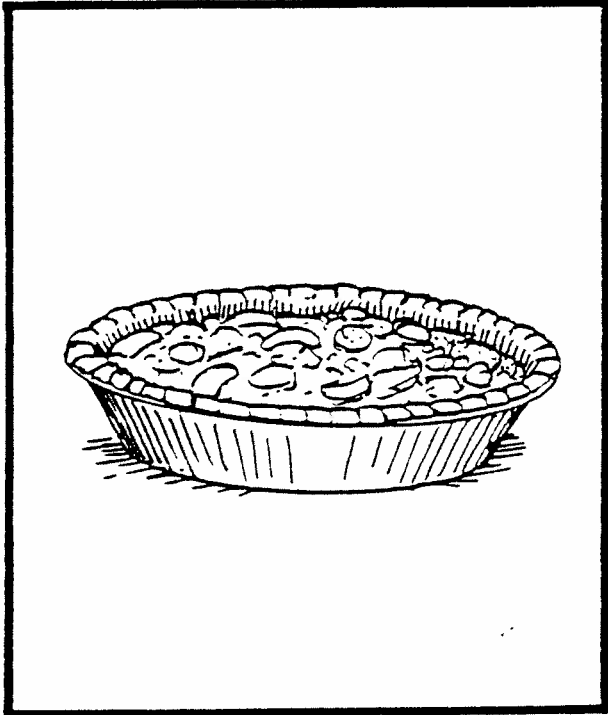

3

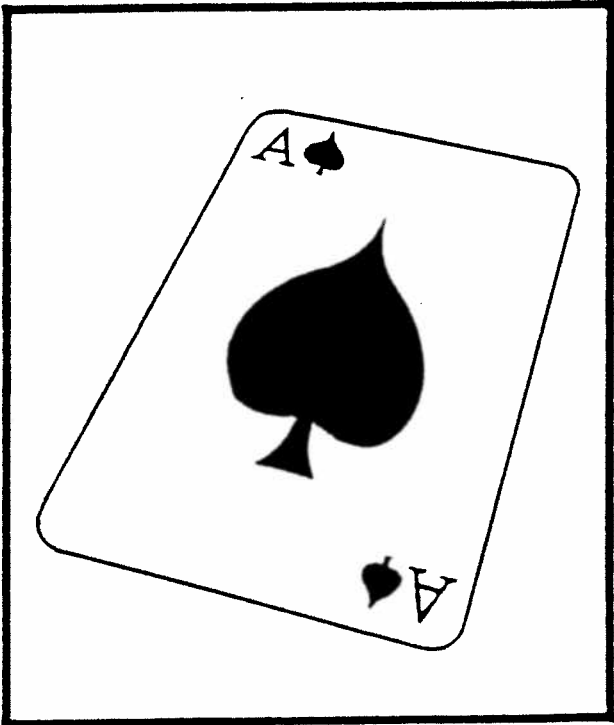

4

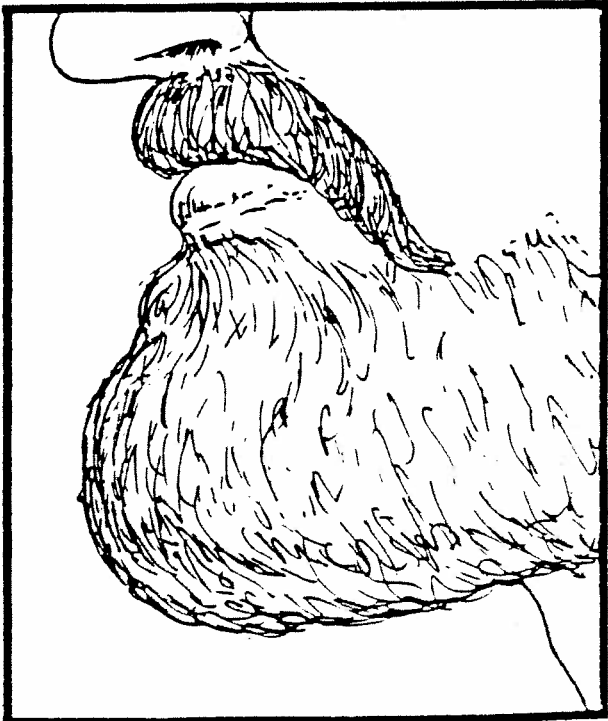

BEGRIPSVERMOGEN VOOR GESCHREVEN ZINNEN

De jongen houdt het meisje vast

1

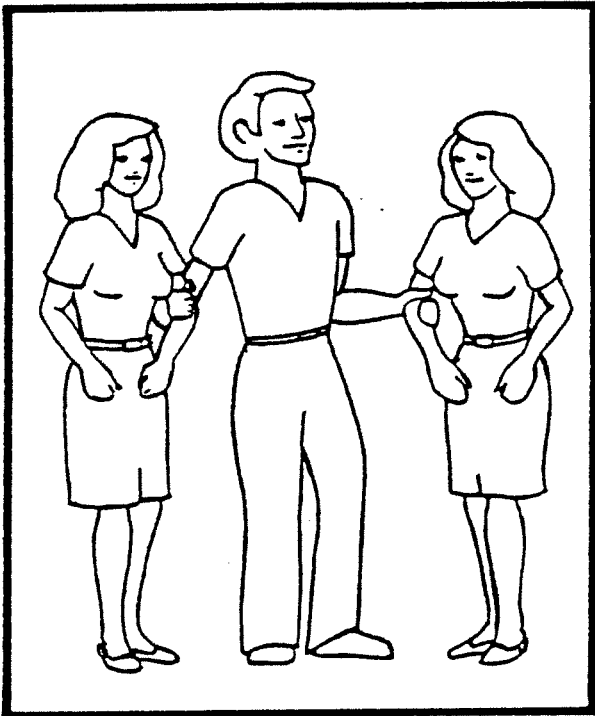

2

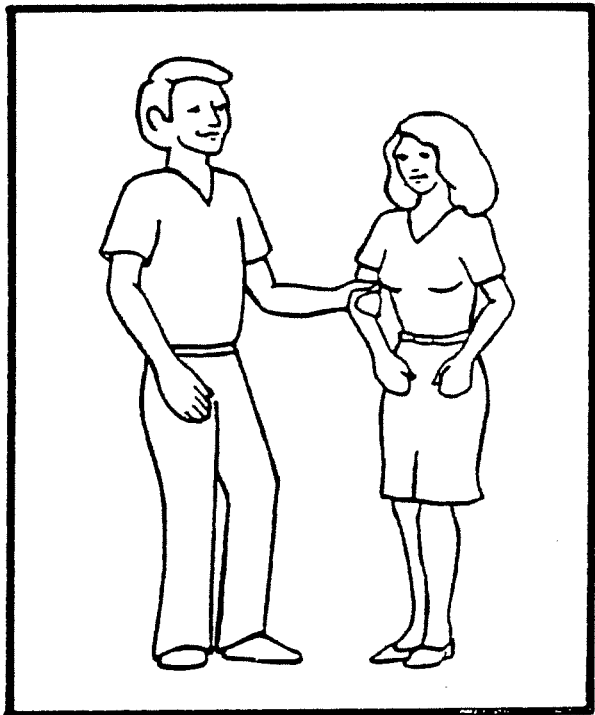

3

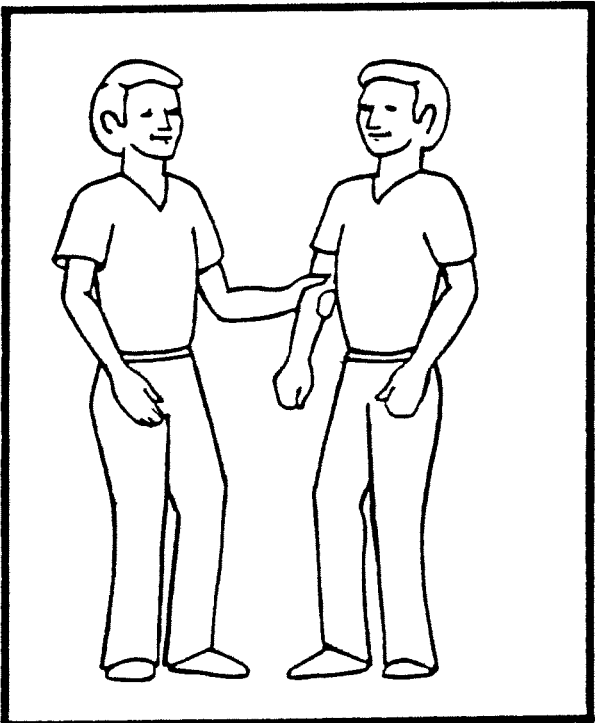

4

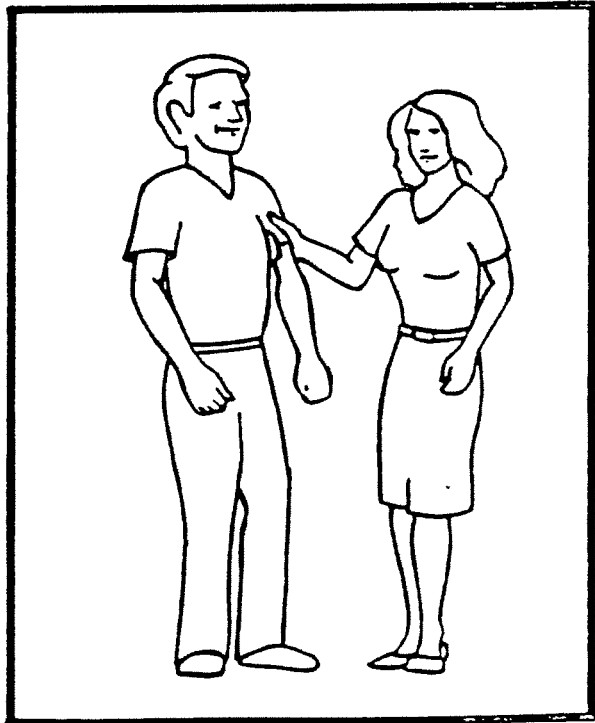

Hij wast zich zelf

1



2

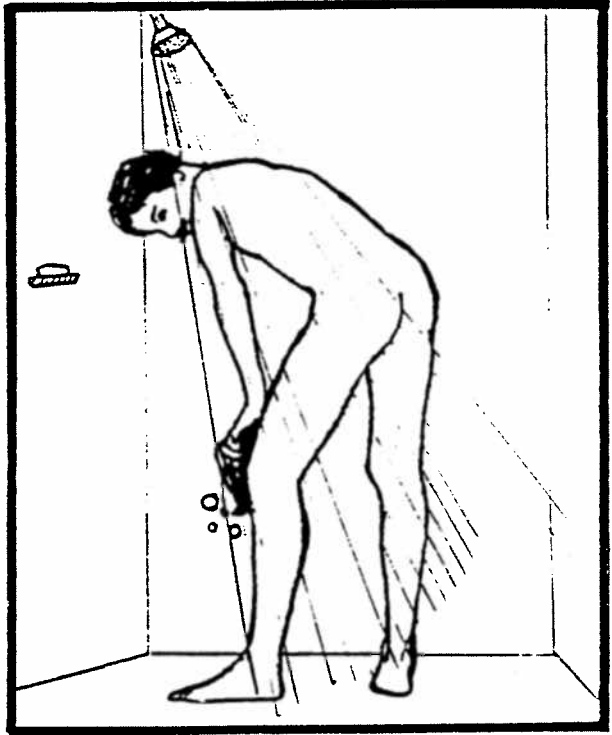

3

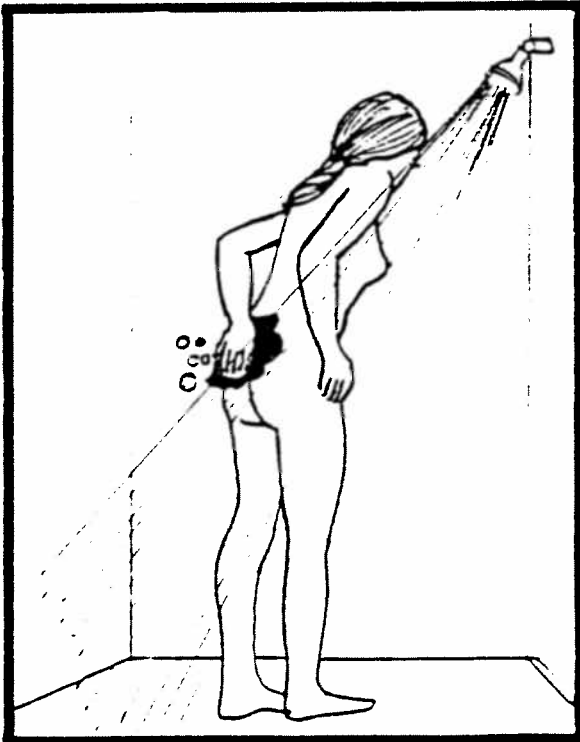

4



De hond wordt door de kat gebeten

1

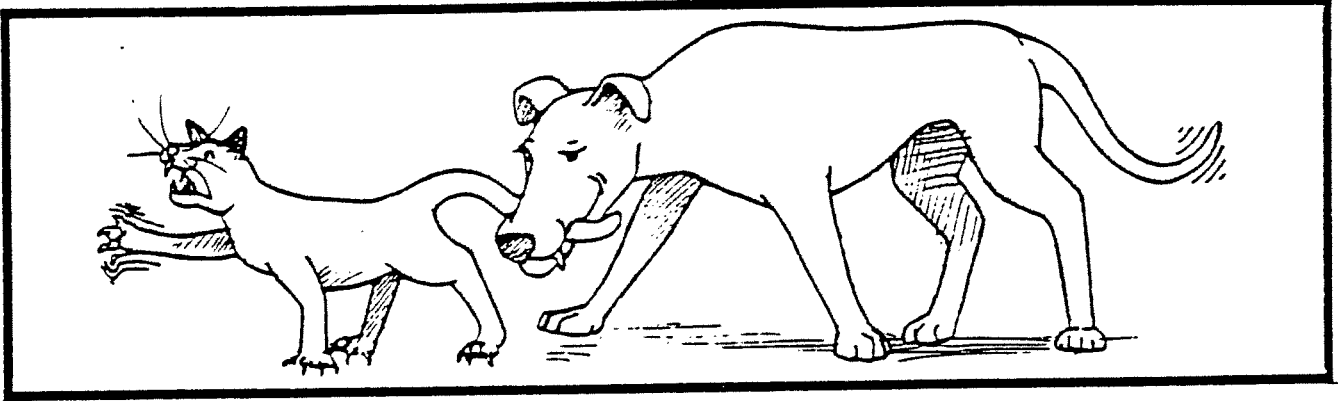

2

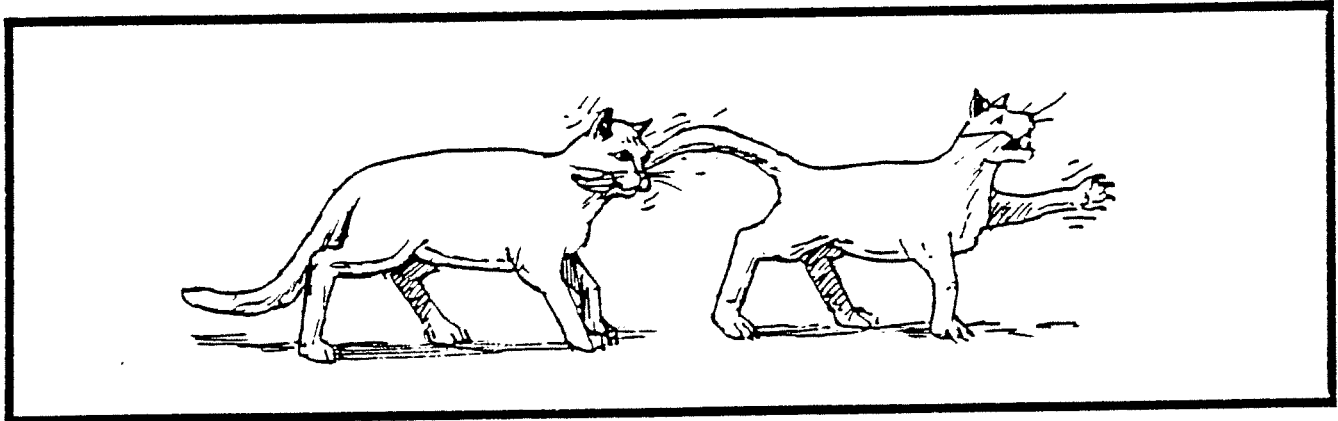

3

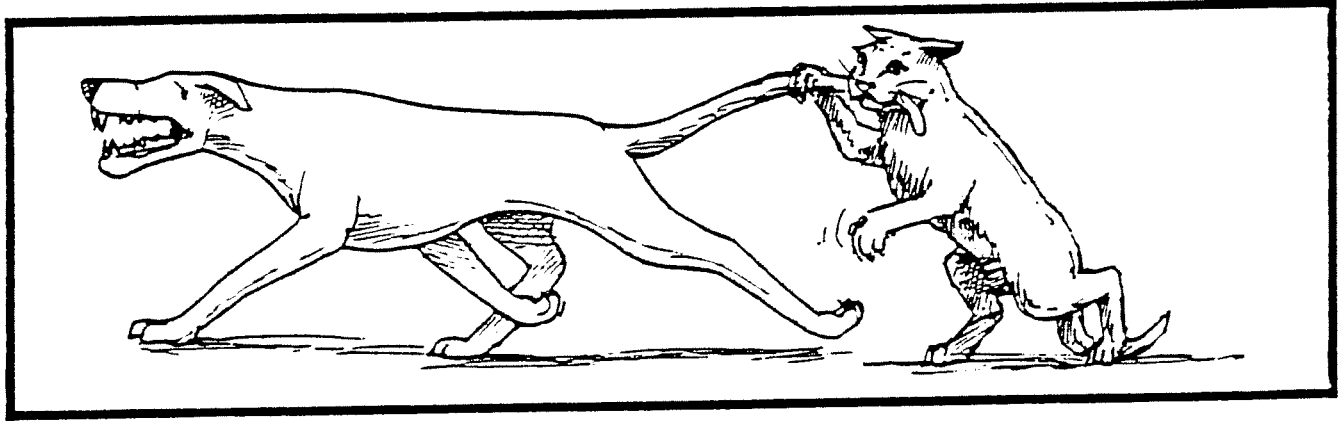

4

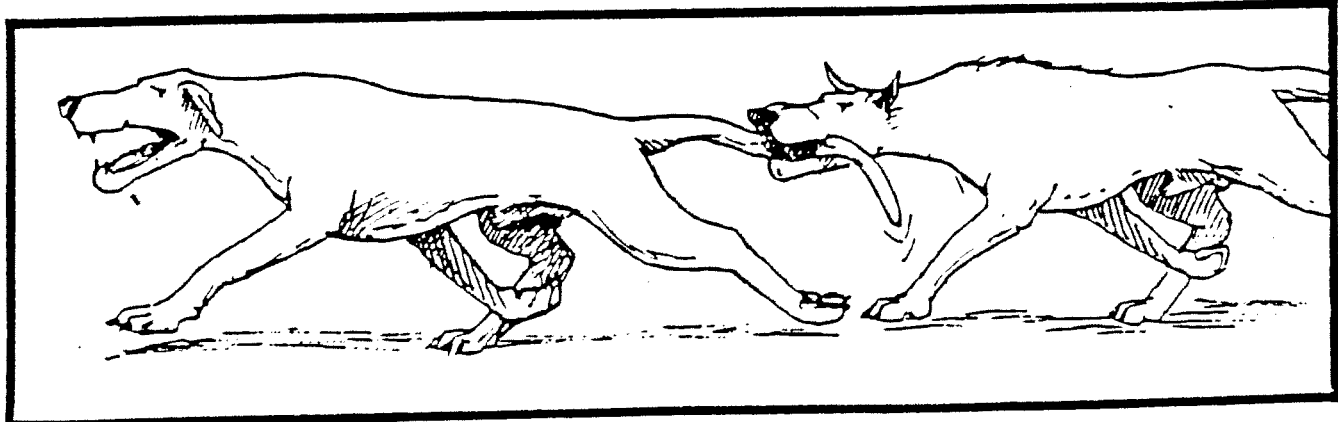

Het is de vrachtwagen die de auto aanrijdt

1

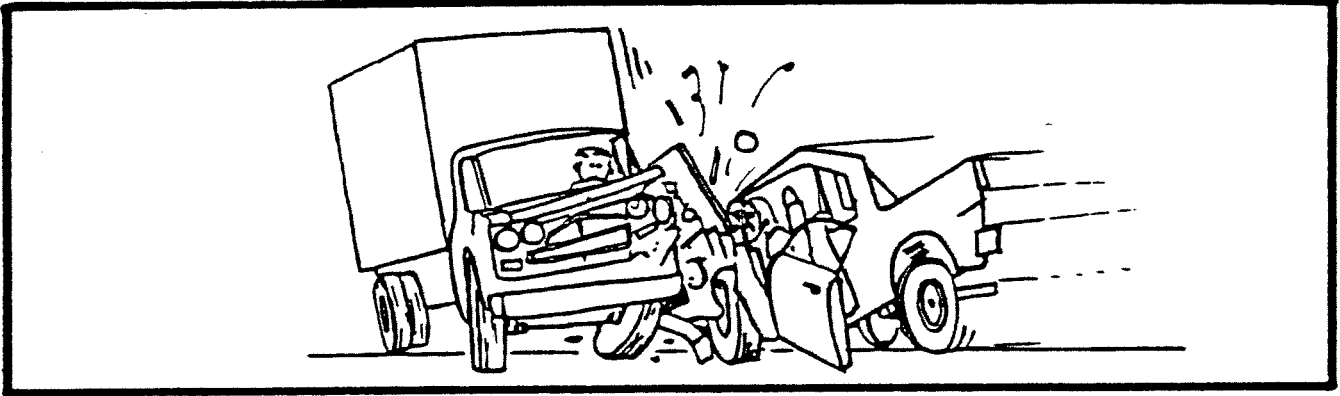

2

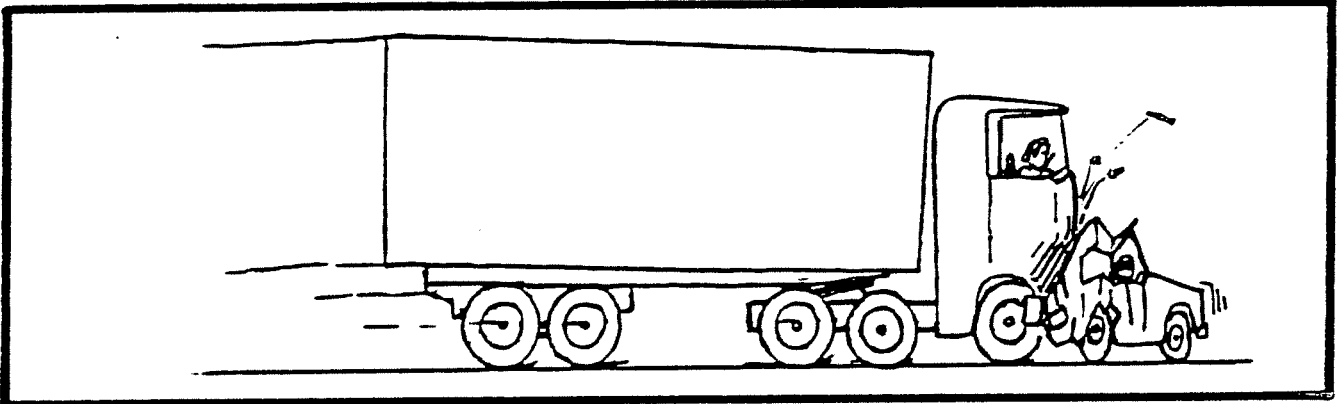

3

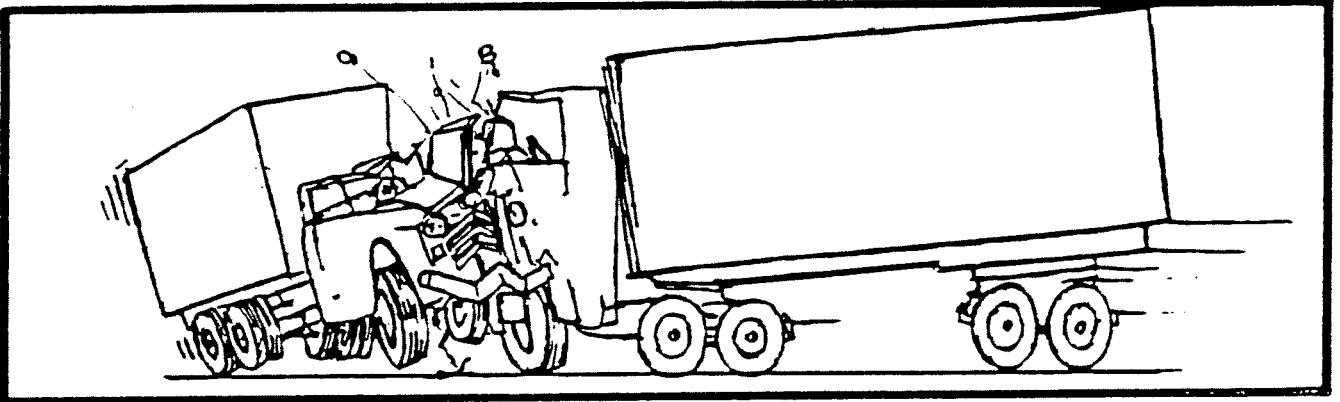

4

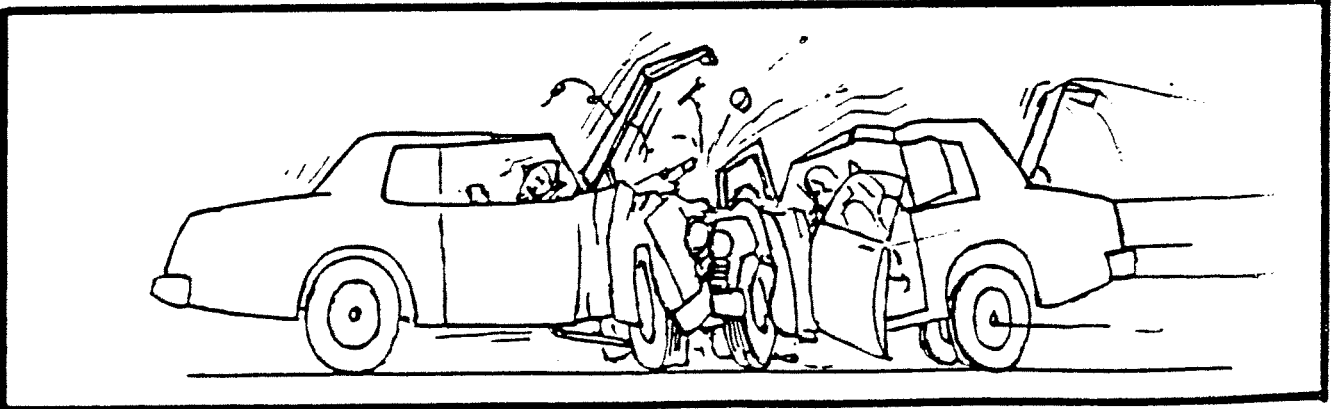

De jongen duwt het meisje niet

1

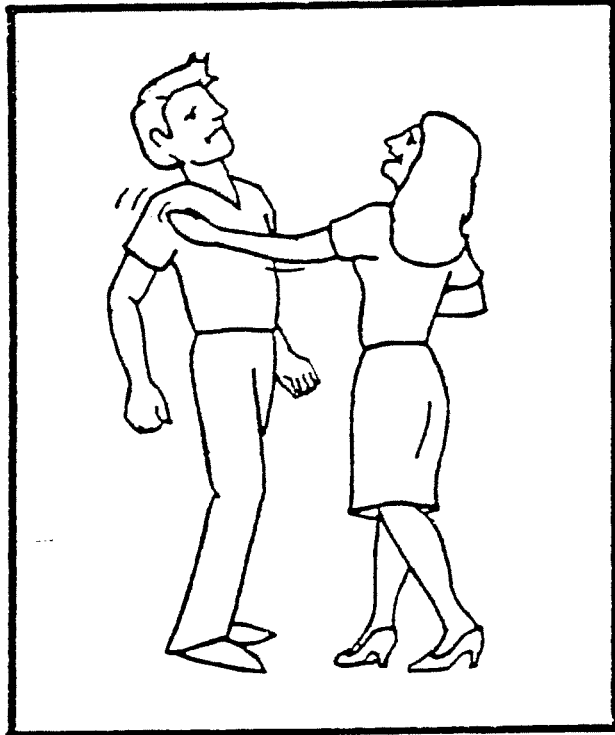

2

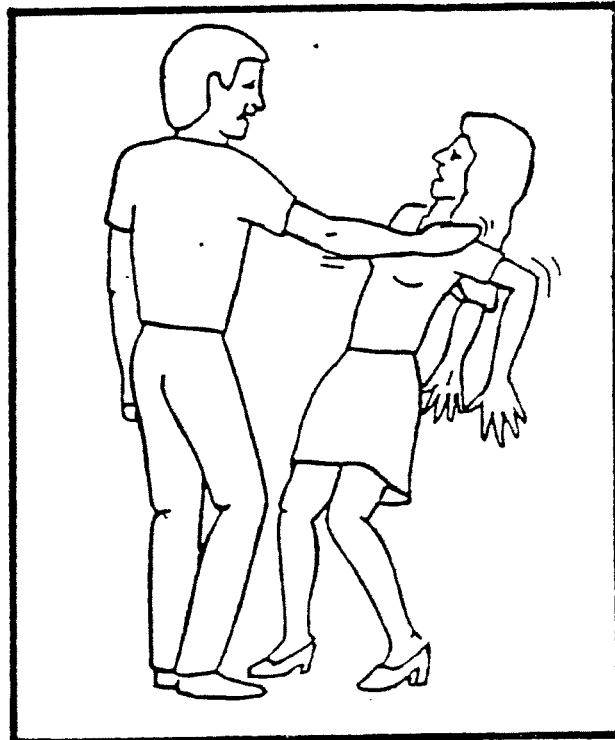

De vrachtwagen wordt niet door de auto gesleept

1

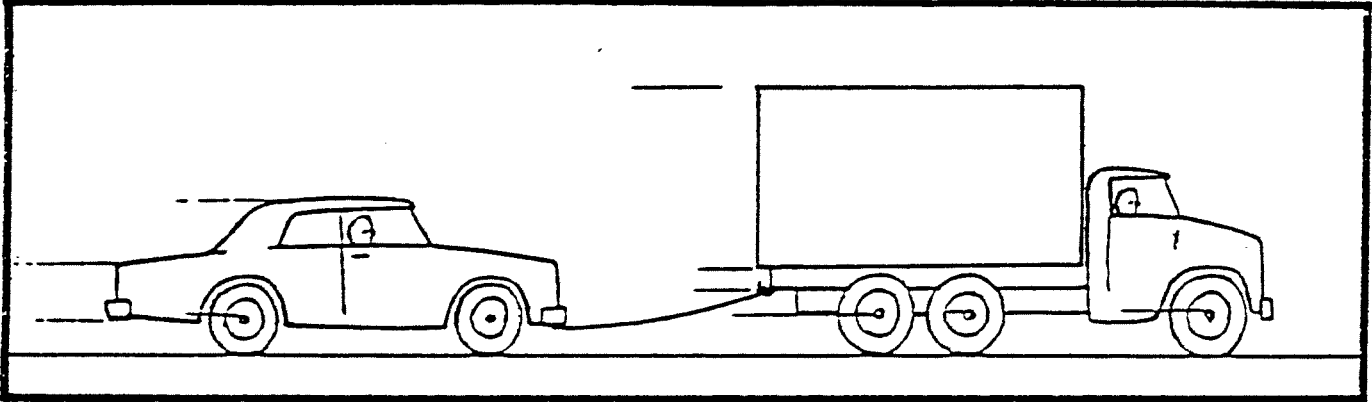

2

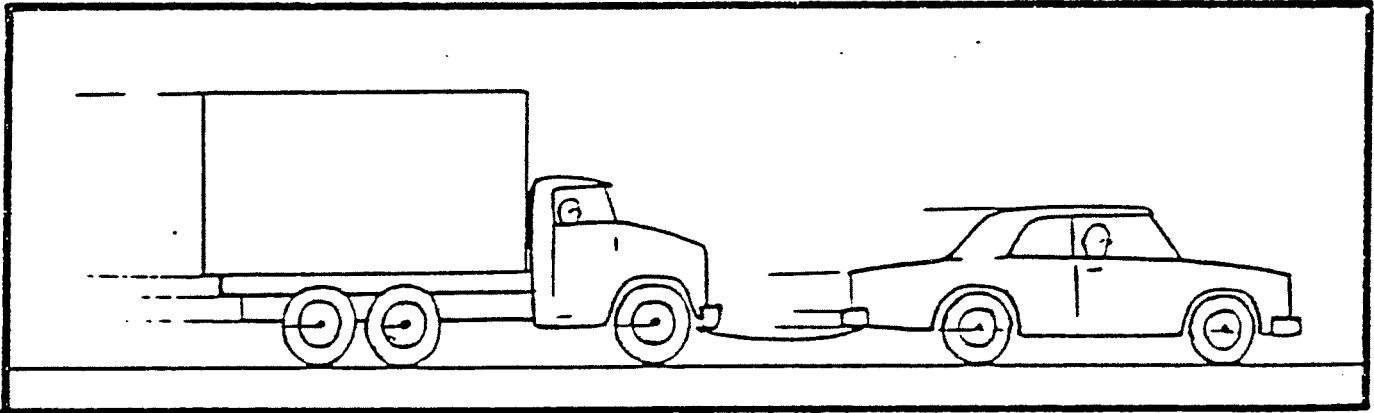

Dat is de kat die de hond bijt

1

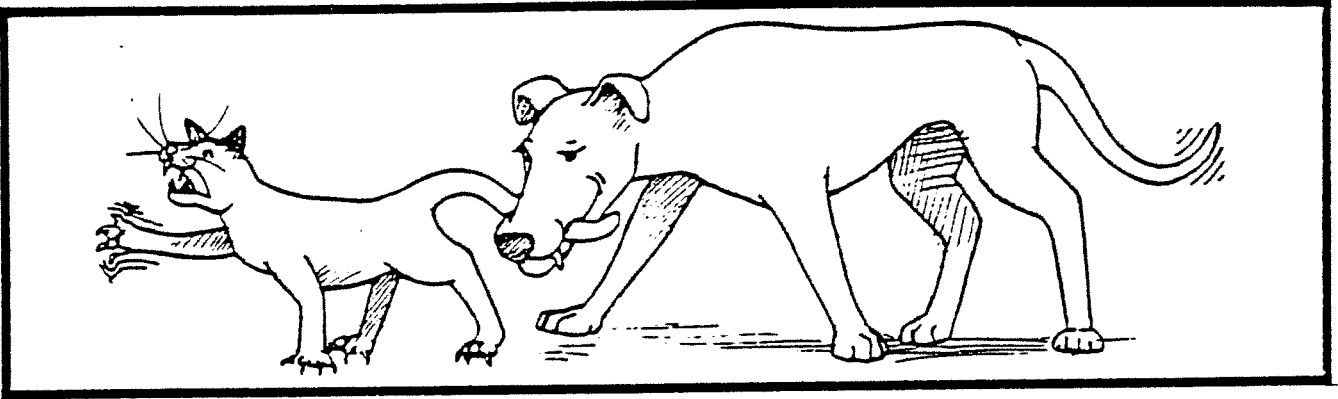

2

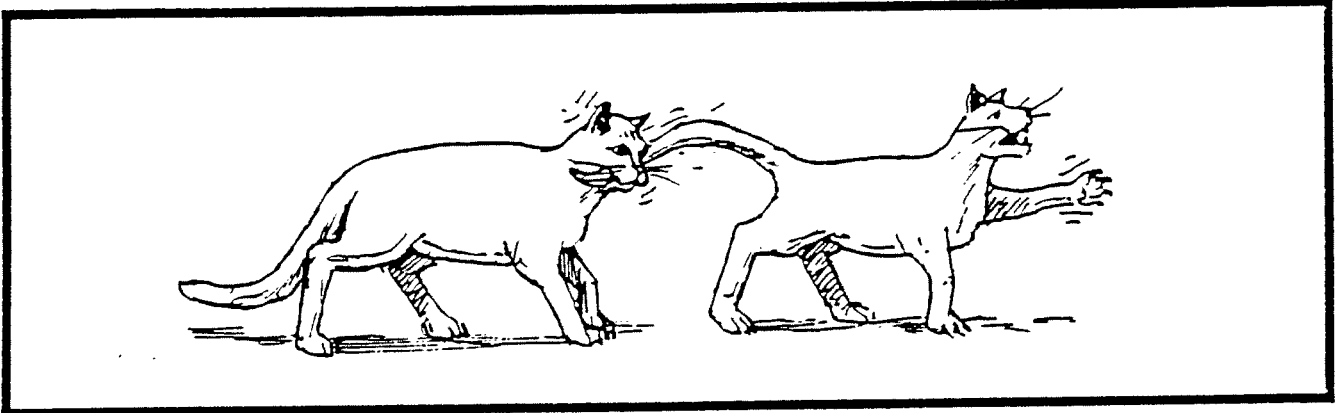

3

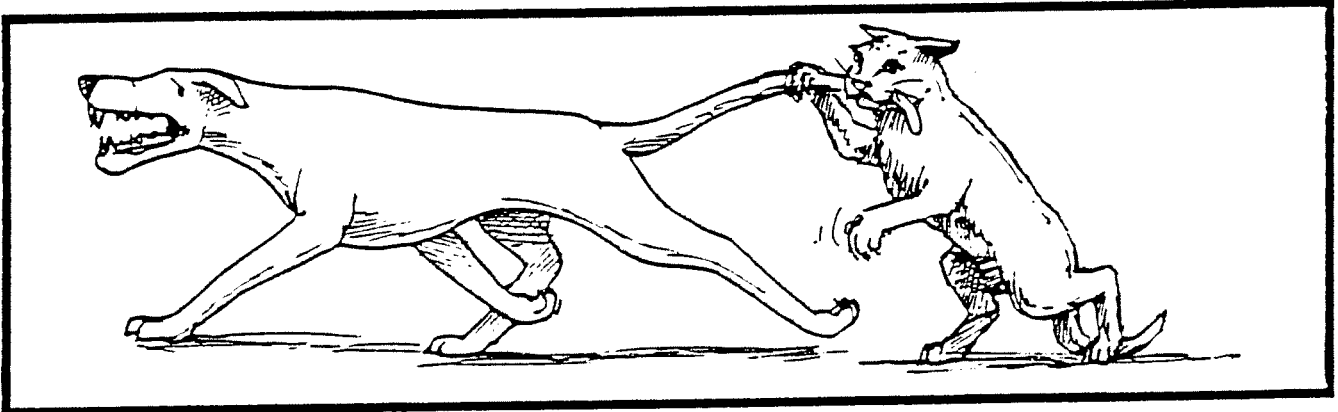

4

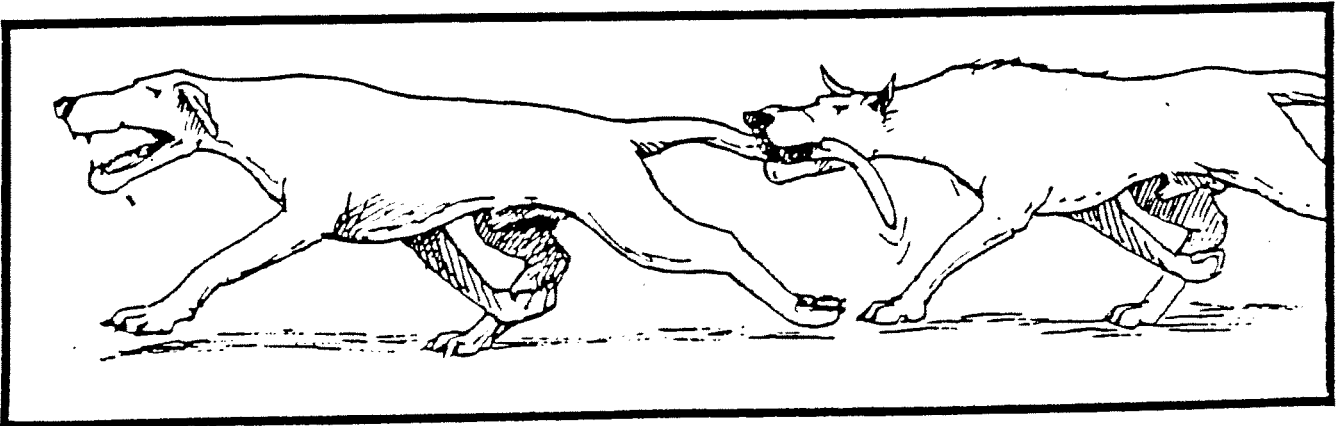

Hij houdt haar vast

1

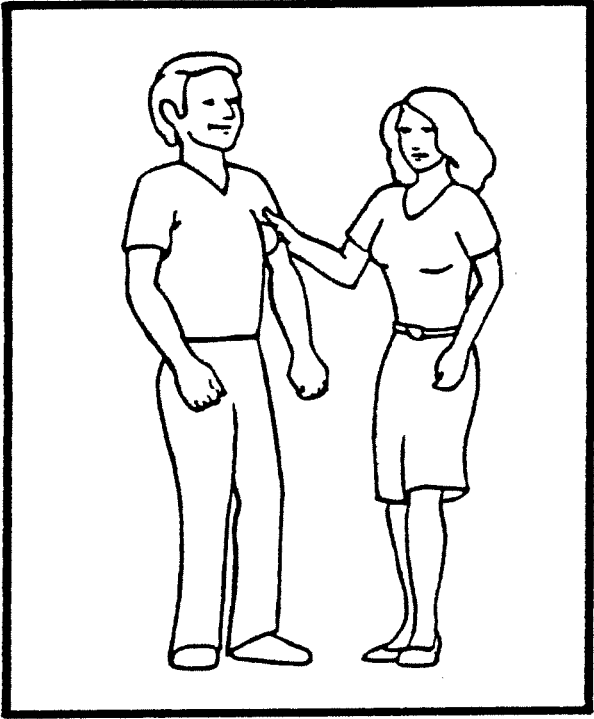

2

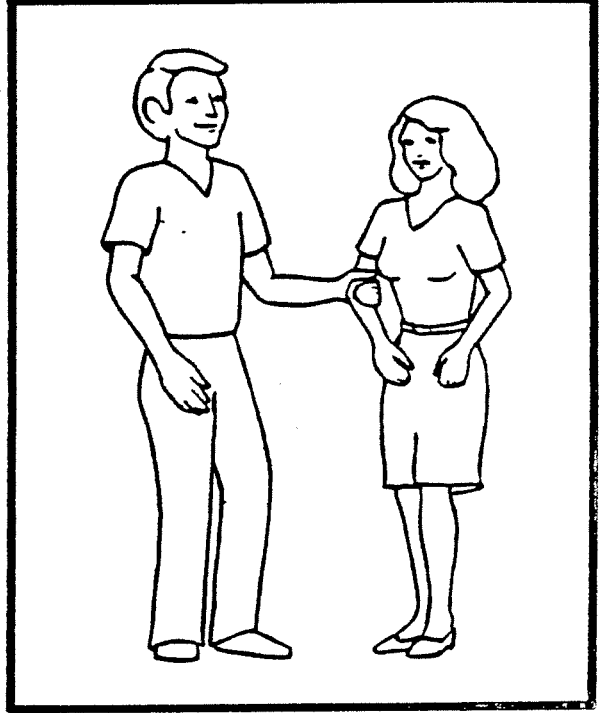

3

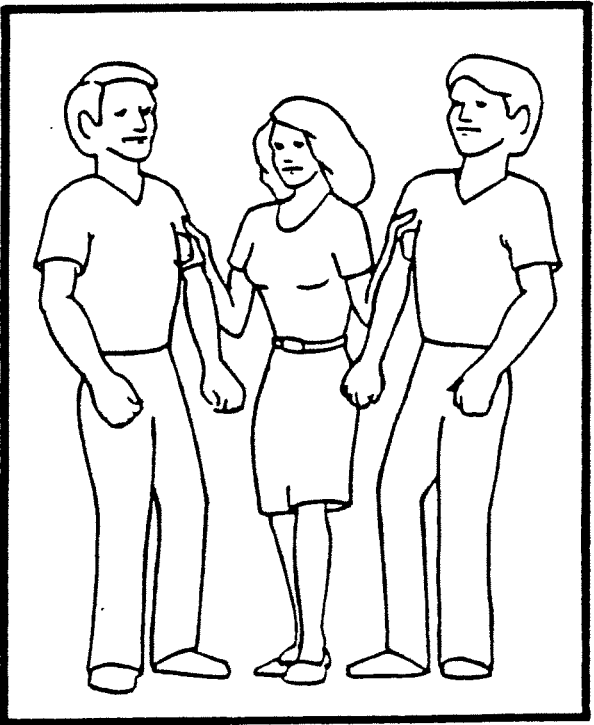

4

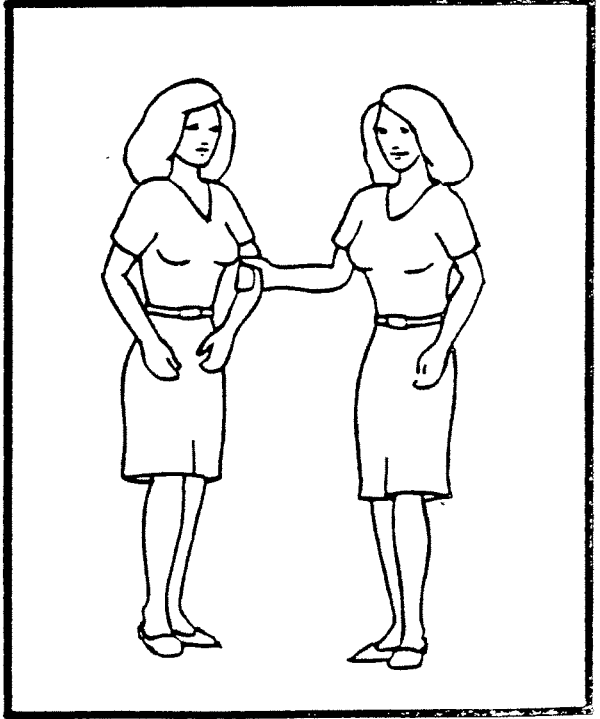

Het meisje wordt door de jongen geduwd

1

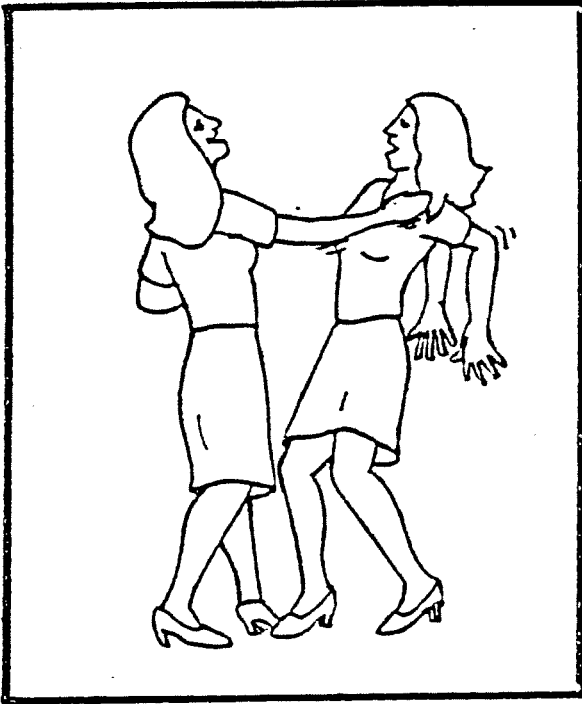

2

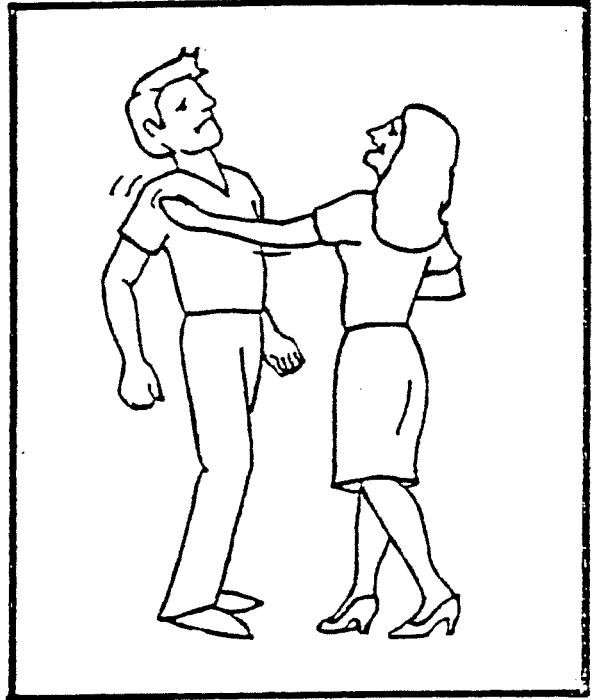

3

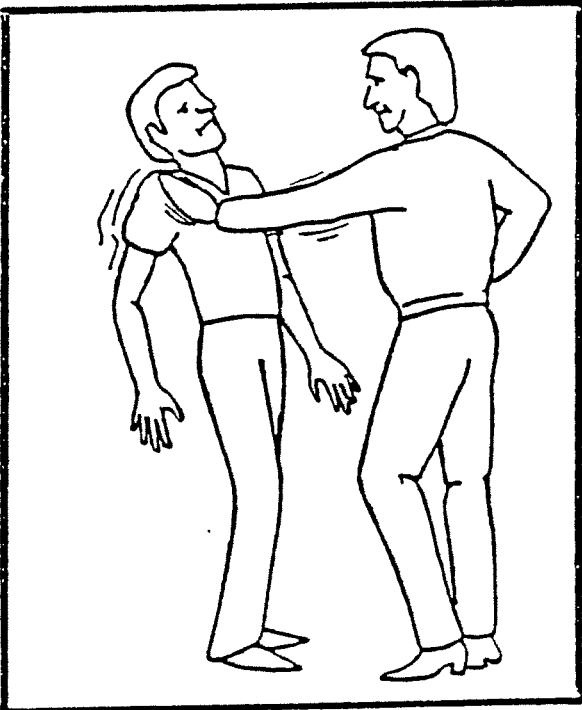

4

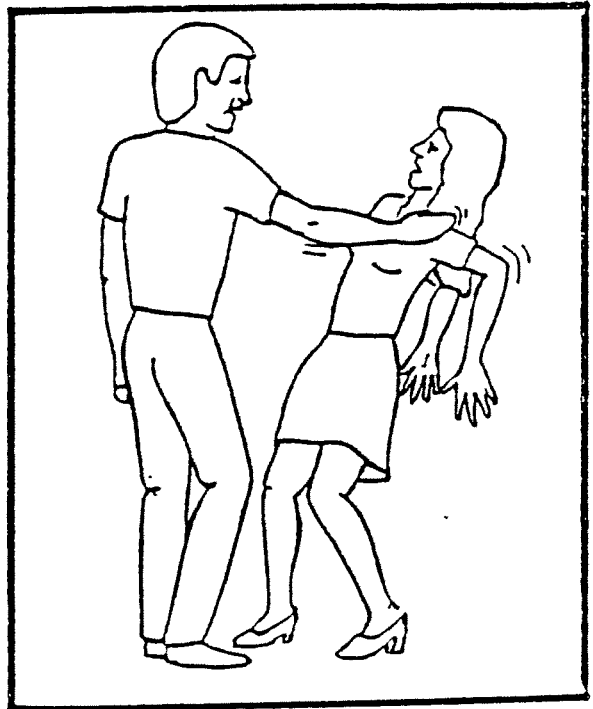

Het meisje wordt door de jongen niet nat gespoten

1

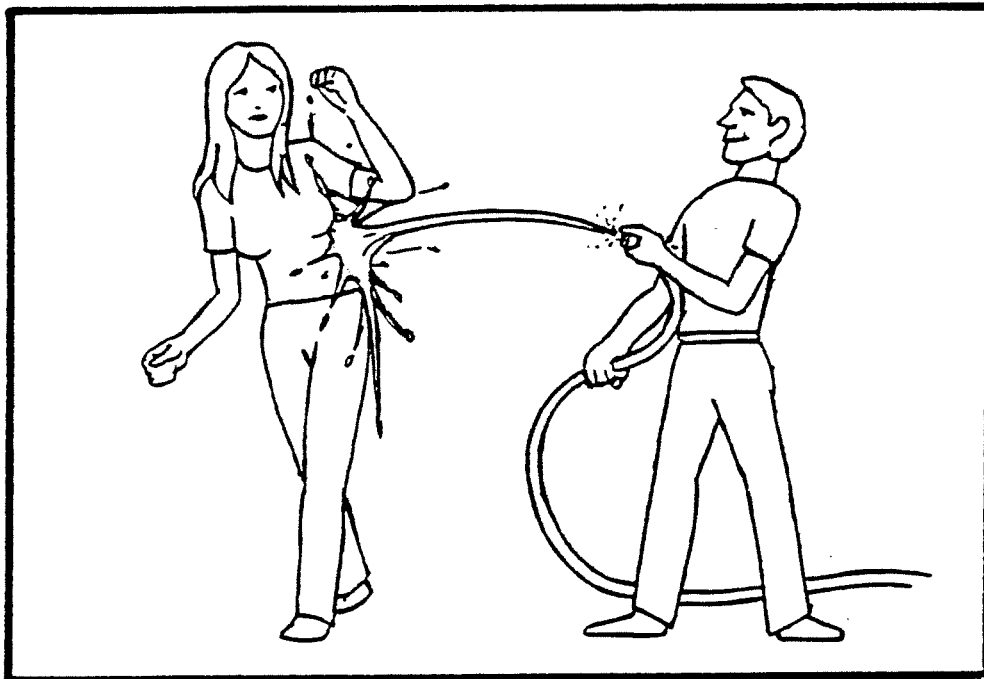

2

